



PROFIBUS Installation Guideline for Cabling and Assembly



Version 1.0.6

Mai 2006



PROFIBUS

Installation Guideline

for Cabling and

Assembly

Version 1.0.6

May 2006

Order No: 8.022

PROFIBUS Guide Order No: 8.022

Identification: Office-04-0007

**This document was created by the ad hoc working group “Installation Guide”
of the PROFIBUS Nutzerorganisation e.V..**

Publisher:

PROFIBUS Nutzerorganisation e.V.

Haid-und-Neu-Str. 7

76131 Karlsruhe

Germany

Phone: +49 721 / 96 58 590

Fax: +49 721 / 96 58 589

info@profibus.com

www.profibus.com

All rights reserved, including reprint, reproduction (photo copy, microfilm), storing in data processing systems, and translation, in whole or in part.

Revision log:

Version	Date	Changes/History
0.2.2	24.06.04	3. Draft distribution for review
0.2.3	20.07.04	Changes according to review of V 0.2.2
0.2.4	09.08.04	Division into three documents (planning, mounting and cabling, commissioning)
0.2.5	19.09.04	Changes according to review of V 0.2.4
0.2.6	15.12.04	Changes according to review of V0.2.5 Chapter 4 "Installation with safety technology (PROFIsafe)" added to the document
0.2.8	18.02.05	WG-Review
1.0.0	28.02.05	Official version created
1.0.1	30.03.05	Minor changes in 2.1 and 2.6.2
1.0.2	20.06.05	Addresses of PCCs replaced by link, Glossary updated
1.0.3	16.11.05	Chapter 2.1, PROFIBUS termination: Fig. 4 revised; Chapter. 2.2.2, M12-plug connections- PROFIBUS RS485: table in Fig. 8 revised,
1.0.4	12.12.05	Chapter 2.2.2, M12-plug connections-MBP (PA) connectors: table in Fig. 11 revised
1.0.5	07.02.06	Renaming of the document from Installation recommendation to Installation Guideline, chapter about capacitive earthing for PROFIBUS-MBP (PA) added
1.0.6	20.05.06	Changes of chapter 2.6.5 according review

Contents

1	Routing PROFIBUS Cables	15
1.1	Routing of PROFIBUS Cables	16
1.1.1	Copper cable	16
1.1.2	Optical fiber cable	29
1.1.3	Redundant PROFIBUS cables.....	29
1.2	Mechanical protection of PROFIBUS cables	30
1.3	Laying the cable.....	31
1.3.1	Electrical PROFIBUS cables.....	31
1.3.2	Laying of optical fiber cables.....	40
2	Assembling PROFIBUS cables.....	49
2.1	PROFIBUS termination.....	50
2.2	Assembling connectors.....	53
2.2.1	9-pin Sub-D connection	53
2.2.2	M-12 plug connections.....	61
2.2.3	Hybrid connectors.....	71
2.3	Direct connection of PROFIBUS stations.....	75
2.4	Flexible PROFIBUS cables.....	78
2.5	Assembling optical fiber cables.....	81
2.5.1	Fiber Connectors for PROFIBUS	82
2.5.2	Plastic optical fiber cable	82
2.5.3	Glass optical fiber cable.....	84
2.6	Grounding and equipotential bonding	86
2.6.1	Protective Earth	86
2.6.2	Functional Earth.....	87
2.6.3	Equipotential bonding	88
2.6.4	Connecting the shielding with the equipotential bonding	91
2.6.5	Equipotential bonding and earthing of PROFIBUS MBP (PA)	95
2.6.6	Connection of shielding to equipotential bonding.....	98
3	Connection of PROFIBUS stations	103
3.1	Static electricity (ESD)	104

3.2	Connecting PROFIBUS stations via plug connections.....	106
4	Installations with safety technology (PROFIsafe).....	109
5	Terms / Definitions	112
6	Index	119
7	References	123

List of Figures

Fig. 1: Cable spacing	17
Fig. 2: PROFIBUS cables outside of buildings.....	28
Fig. 3: Routing redundant PROFIBUS cables.....	29
Fig. 4: Bus termination PROFIBUS RS 485.....	50
Fig. 5: Bus termination PROFIBUS MBP (PA).....	50
Fig. 6: termination on / incoming and outgoing cable not connected	51
Fig. 7: Bus termination off / incoming cable and outgoing cable connected	52
Fig. 8: pin assignment of 9-pin Sub-D-connector front side	55
Fig. 9: 5-pin M-12 female socket (PROFIBUS-RS 485).....	61
Fig. 10: 5 pin M-12 male plug for RS 485	62
Fig. 11: 4-pin M-12 connector (for MBP (PA)) – male plug (left) and female socket (right)	63
Fig. 12: Pin assignment for Hybrid connector by Desina	72
Fig. 13: Screw terminals – suitable for stranded cables without wire-end ferrules	78
Fig. 14: Screw terminals – not suitable for stranded cables without wire-end ferrules	78
Fig. 15: BFOC/2.5 type connector (ST connector).....	82
Fig. 16: Ideal connection of cable shields to the equipotential bonding	95
Fig. 17: Capacitive earthing for PROFIBUS-MBP (PA).....	96
Fig. 18: Techniques for connecting the cable shield to equipotential bonding	98

List of Tables

Table 1: Minimum spacing for cables (according to EN 50174).....	18
Table 2: Optical fiber cables for PROFIBUS.....	81

Preface

There are already a large number of documents available for PROFIBUS. So why is the Installation Guideline for Cabling and Assembly being added now? The answer is very simple: The existing documents have been created at different times and therefore feature a different structure. In addition, they contain extensive specifications directed at PROFIBUS device developers. This information is not required for users and can be more confusing than helpful.

As the name indicates, the Installation Guideline for Cabling and Assembly is intended to provide information on how to properly install PROFIBUS wiring and to provide practical guidance on the best ways to achieve this.

The presentation of information in this document has been kept as simple as possible. Accordingly, background knowledge about PROFIBUS mounting and cabling is not required. However, a basic technical knowledge of electrical installation is assumed.

The operating principle of PROFIBUS is not discussed in the Installation Guideline for Cabling and Assembly. If you require this information, please use the respective documents of the PROFIBUS Nutzerorganisation e.V. or corresponding technical literature.

This document does not replace any existing document. The previous documents of the PNO remain in effect.

Safety information



The use of the PROFIBUS Installation Guideline for Cabling and Assembly may involve handling hazardous materials or tools or involve dangerous work. Due to the many and diverse applications of PROFIBUS, it is not possible to take all options or safety requirements into consideration. Each application makes different demands on the installer. In order to competently judge possible dangers, you must inform yourself about the safety requirements of the respective system before starting your work. Special attention must be paid to the laws and regulations of the respective country in which the system will be operated. You should also observe general health and safety requirements, as well as the requirements of the company for which the system is being installed. In addition the manufacturer supplied documentation for the PROFIBUS components used must be considered.

Electrical safety during the assembling and cabling

Isolation from supply during assembling and cabling

Ensure isolation from supply voltage before assembling electrical components.

Touching a stripped core that is under supply voltage can lead to severe burns and even to death.



In addition, a short circuit can cause severe equipment damage.

Cable damage

Damaged cables represent a high risk. They can energize system components, thereby creating the risk of machine or plant damage. In addition, damaged cables can introduce the risk of injury or death from electric shock. For this reason, damaged cables should always be replaced.

Disclaimer of liability

This document is intended for information purposes only and is made available on the basis of a disclaimer of warranty. The document may be subject to changes, expansions or corrections in the future without specific notice. The PROFIBUS Nutzerorganisation e.V. expressly rejects any form of contractual or legal liability for this document, including the warranty for defects and the warranty of usage qualities. In no case will the PROFIBUS Nutzerorganisation e.V. be responsible for any losses or damages that occur or result from any type of defect, fault or omission in this document or from the use or reliance on this document by anyone.

Reference standards

EN 50174-2 (2000)

Information technology - Cabling installation - Part 2: Installation planning and practices inside buildings

EN 50174-3 (2003)

Information technology - Cabling installation - Part 3: Installation planning and practices outside buildings

IEC 60364-5-54 (2002)

Electrical installations of buildings - Part 5-54: Selection and erection of electrical equipment - Earthing arrangements, protective conductors and protective bonding conductors

IEC 61158-2 (2003)

Digital data communication for measurement and control – Fieldbus for use in industrial control systems, Part 2 Physical Layer Specification and Service Definition

IEC 61784-1

Digital data communications for measurement and control - Part 1: Profile sets for continuous and discrete manufacturing relative to fieldbus use in industrial control systems

Explanation of symbols

This document contains many illustrations which are intended to facilitate understanding of the text. The illustrations are generally displayed in black and white. The color violet is used only for emphasizing important details. The following field shows the color used.



The following line shape is used to display equipotential bonding and grounding cable.



In addition, the following symbol is used to display a functional earth connection
Note: The functional earth shall not be used as protective earth



Furthermore, the following symbols are used. They provide a reference to particularly important text passages.



Danger!

The symbol points to a danger for life and health. Observing the instruction is extremely important!



Caution!

The symbol points to a danger for damage to property. Observing the instruction is intended to avoid property or equipment damage.

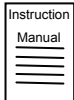

Manufacturer instruction

The symbol on the left indicates when you must follow the instructions of the manufacturer. In this case, the information in this installation guideline is secondary to the manufacturer's information.



Note

The symbol points to the risk of interference. Observing the note reduces the risk of interference or pickup.



Tip

Tips provide practical notes that facilitate your work and improve the system setup.

1 Routing PROFIBUS Cables

1.1 Routing of PROFIBUS Cables

1.1.1 Copper cable

General plant or factory cabling can carry high voltages and currents. Running PROFIBUS cables parallel to such cables can lead to interference pickup and thus to data transmission errors. Interference can be reduced by separating the PROFIBUS cable from the interference source and also by minimizing the length of any parallel runs of cable.

Telecommunication cable

Special rules apply to public telecommunication cables (telephone cables, etc.). In this case, the country-specific regulations must be observed (in many countries, telecommunication cables must not be routed together with other cables).

Boundary conditions

Classifying the cables according to voltage classes is based on the assumption that the interference voltages carried along are lower the lower the carried voltages and currents are. For this reason, data transmission cables are generally without risk. Particularly critical are interference voltages in the kHz to MHz range. High-frequency interference can also arise on power supply cables with direct voltage or 50/60-Hz alternating voltage when the supply is switched, e.g. through a frequently switching relay or an inverter.

Cable spacing

Table 1: Minimum spacing for cables (according to EN 50174) shows the distances according to EN 50174-2 that must be maintained between PROFIBUS cables (shielded data cable) and other cables. The table also lists two variants with a metal isolating segment. Here, it is assumed that a metal partition has the same effect as a cable shield.



In general, the greater the spacing between the cables and the shorter the paths run parallel, the lower the risks of interference (crosstalk).

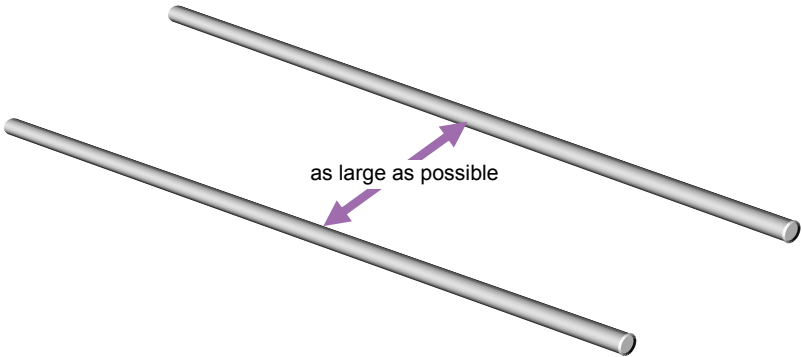

Fig. 1: Cable spacing

How to read the table

To determine the minimum distance between PROFIBUS cables and other electrical cables, proceed as follows:

1. In the left column (PROFIBUS cable and cable for...) select which electrical cables you want to route together with the PROFIBUS cables.
2. In the right table section (spacing), select the type of cable separation to be used.
3. The spacing for the respective cable type routing can be found in the column with the respective type of cable separation.
4. In addition, observe the regulations for the different routing areas found below Table 1.

Table 1: Minimum spacing for cables (according to EN 50174)

PROFIBUS cable and cable for	Spacing		
	Without partition or with non-metallic partition	Partition made out of aluminum	Partition made out of steel
Signal transmission			
<ul style="list-style-type: none"> • Network signals such as PROFIBUS. • Digital data signals for PCs, programming devices, printers, etc. • Shielded analog inputs or outputs 	0 mm	0 mm	0 mm
Power supply			
<ul style="list-style-type: none"> • Unshielded 	200 mm	100 mm	50 mm
<ul style="list-style-type: none"> • Shielded 	0 mm	0 mm	0 mm

Cable routing inside of control cabinets

- The minimum spacing between cables should be adhered to even for cables routed within control cabinets. Table 1: Minimum spacing for cables (according to EN 50174).
- Where cables must cross they should always do so at right angles.
- If the space is insufficient to maintain the required spacing between the individual categories, the cables must be routed in separate, metallic trays. Each tray must hold only cables of the same category. These trays can then be arranged directly next to each other.

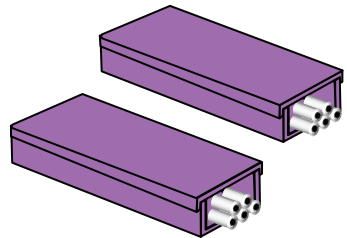
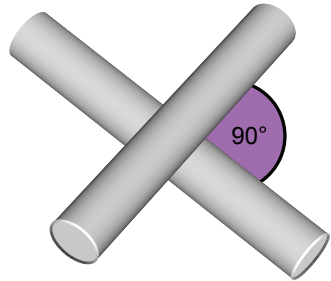

- The metal cable tray must be screwed to the uprights of the frame or the cabinet walls approximately every 50 cm. Ensure that a large well-conducting area is created between uprights and cable tray. If the cabinet walls are painted or coated, this can be accomplished by using toothed lock washers or removing the coating or paint.

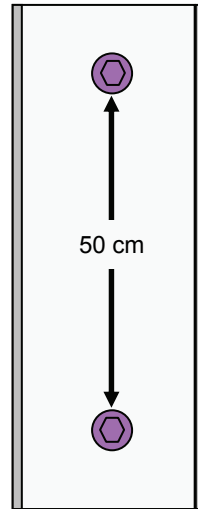

- Ground the shields of all cables entering the cabinet at the entry point. Connect the shield to the cabinet ground with the greatest possible surface area. Special mounting clips are available from various manufacturers for this purpose. In order to protect the cables from being damaged by mechanical stress, the cables should be fixed above and below the grounding clip

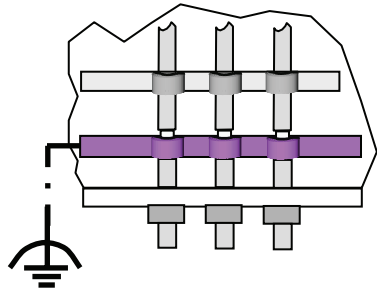

- Use threaded glands where the cable enters the control cabinet.

Routing PROFIBUS cables

- Avoid running any cables that pass outside the cabinet in parallel with PROFIBUS cables before the cable shield is earthed. This also applies to cables of the same category!

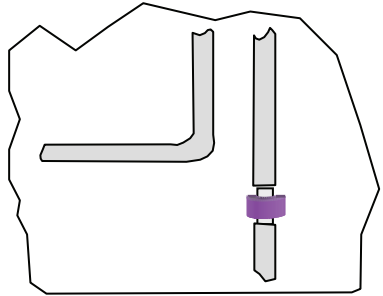

OK

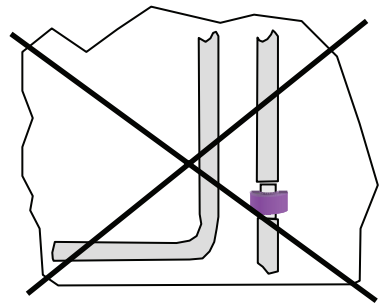

No

Cable routing inside buildings

The following must be observed when routing cables outside of control cabinets and inside of buildings:

- The minimum spacing between two cables can be found in Table 1: Minimum spacing for cables (according to EN 50174). In general, the risk of crosstalk is the lower, the greater the separation between the cables.
- If the cables are routed in metal cable trays, the trays can be arranged directly next to each other.
- If only one common metal cable tray is available for all categories, the spacing according to Table 1 must be followed. If this is not possible due to space, the different cable categories must be separated by using metal separators or partitions. The separators must be well-bonded to the tray with a large surface area.

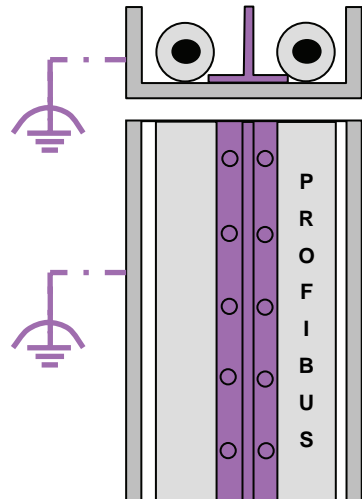
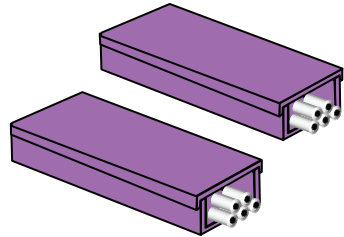

- Where cables must cross they should always do so at right angles.

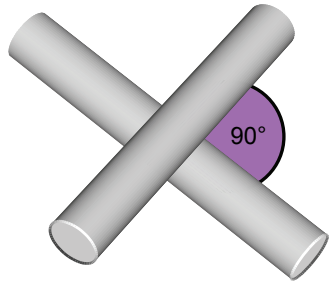

- The individual sub-system grounds and all metal cable trays must be connected to the building equipotential bonding system.

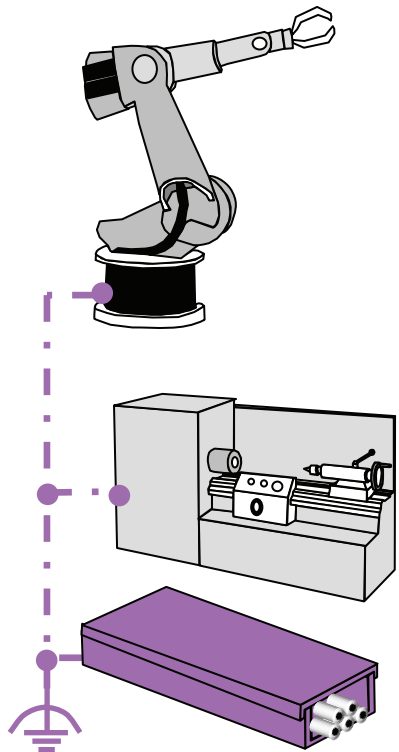

- For this purpose, observe the notes about equipotential bonding in Chapter 2.6 of this guide.

Cable routing outside buildings



It is recommended that optical fiber cables are used for PROFIBUS connections outside of buildings, because of their immunity to electromagnetic interference. Because optical fiber cables provide electrical isolation, equipotential bonding can then be omitted.



Use only approved cables for the routing outside of buildings. This applies particularly to routing in the ground.

For interference-immune routing of PROFIBUS cables outside of buildings, the same rules must be followed as those for cable routing inside of buildings. Additionally, the following applies:

- Route the cables on cable racks with good conductivity. Mesh openings shall be small.
- Connect the butt joints of the cable racks with a large surface area, forming a good conduction. Ensure that the connection is made from the same material as the cable rack (do not mix materials).

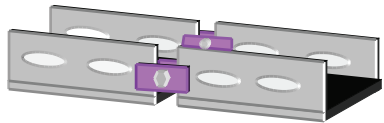

- Ground the cable rack.

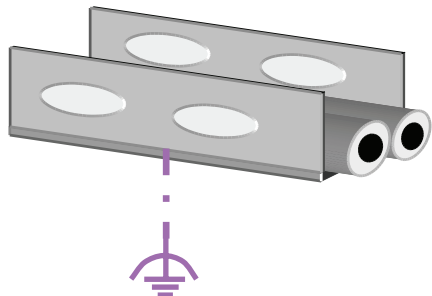

Routing PROFIBUS cables

A sufficient equipotential bonding must be ensured between the buildings and external facilities, independent of the PROFIBUS cables. According to IEC 60364-5-54, the following cross sections are required:

- Copper 6 mm²
- Aluminum 16 mm²
- Steel 50 mm²

- Route the PROFIBUS cables in parallel with and as close as possible to the equipotential bonding cable.

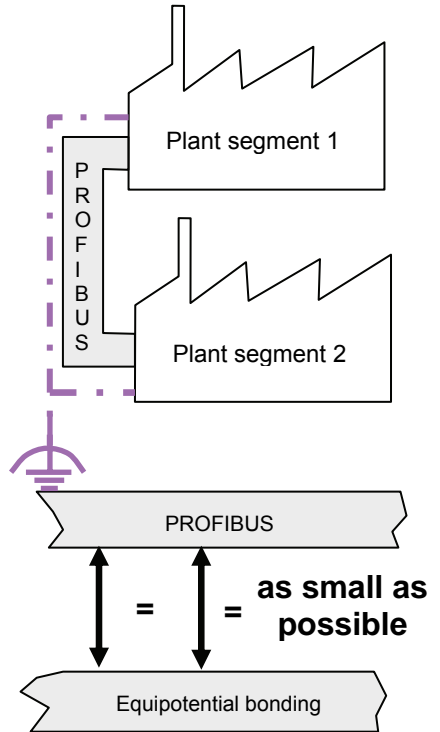

- Connect the shields of the PROFIBUS cables to the building grounding system as close as possible to the cable entry point.

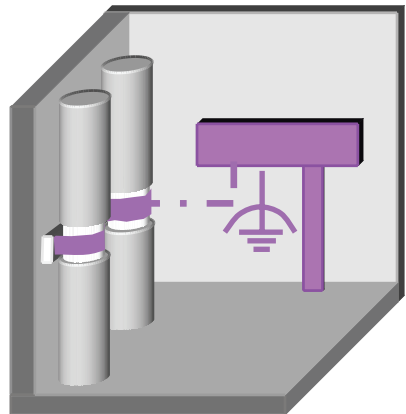

- Use an auxiliary metal terminal box between outside and inside systems (crossing from direct-buried cable to standard bus cable).
- Ground the auxiliary terminal box.
- Integrate PROFIBUS cables routed outside of buildings in the lightning and over-voltage protection system. The planning of the lightning and over-voltage protection system should be done by a specialist company.

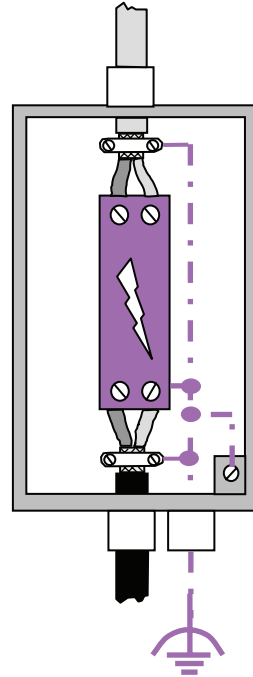

Use an over voltage-protector between the standard bus cable and the direct-buried cable.

Routing in the ground



Cables that must be routed in the ground must have a very robust construction. For this reason, ground routing should only use PROFIBUS cables approved by the manufacturer for routing in the ground.

In addition, the following is recommended for direct routing in the ground:

Routing PROFIBUS cables

- Route the PROFIBUS cable in a trench approximately 60cm below the surface.

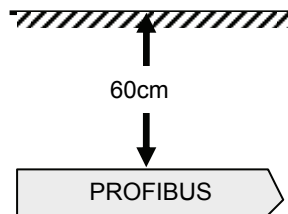

- Protect the PROFIBUS cable against mechanical damage, e.g. by using a plastic pipe. Place cable warning tape above it (approximately 20cm below the surface).

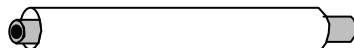
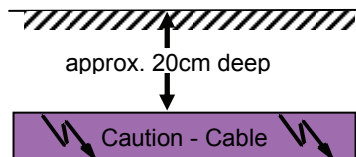

- Route the equipotential bonding between the buildings approximately 20 cm above the PROFIBUS cable (e.g. galvanized ground strip). The ground strip is also used as protection against the effects of a lightning strike. The minimum cross section for the equipotential bonding according to IEC 60364-5-54 is:

- o Steel 50 mm²

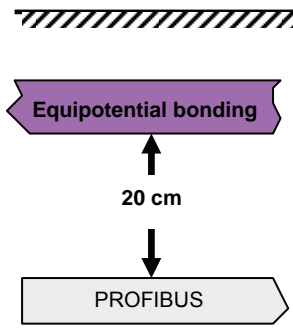

- If several cables of different categories are routed in the same trench, maintain as spacers.

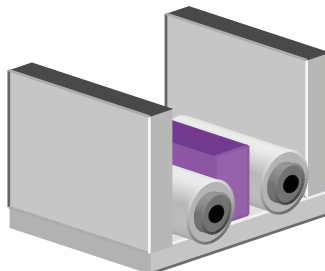

Routing PROFIBUS cables

- Maintain a minimum distance of 30 cm to power supply cables up to a voltage of 1000 V, unless other regulations require a greater distance. Pertinent information about this topic can be found in EN 50174-3:2003. For higher voltages, please observe the corresponding standards and regulations.

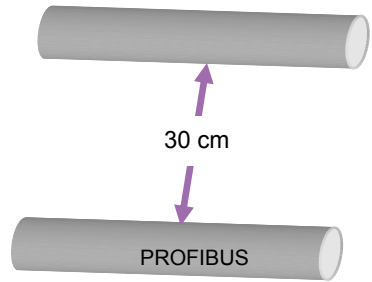

During excavation, watch for indicators to other cables or devices (e.g. cable warning tape). Damage to another cable or device (e.g. power supply cables, gas lines) can lead to property damage as well as to risk of health and life.

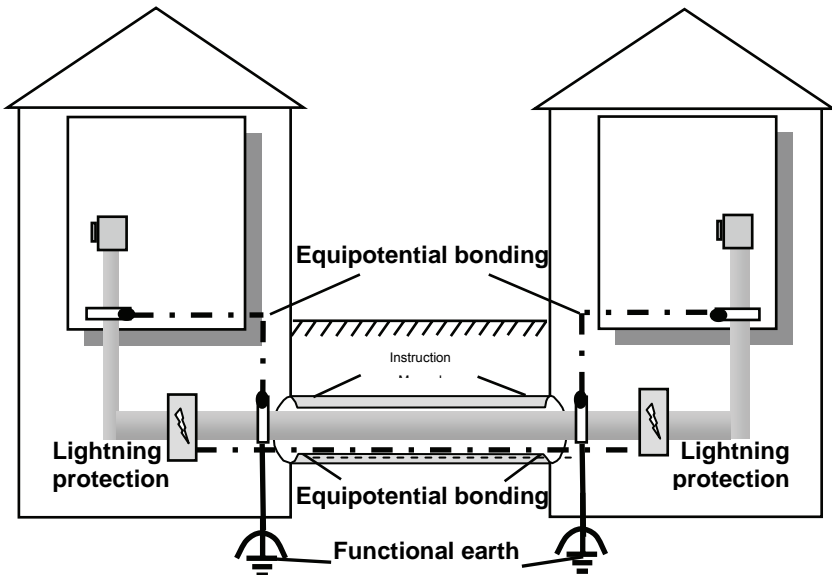

Fig. 2: PROFIBUS cables outside of buildings

1.1.2 Optical fiber cable

Because optical fiber cables provide galvanic isolation and are immune to electromagnetic pickup (EMC interference), their routing is simpler than for copper cables. However, optical fiber cables must be mechanically protected. In addition, the optical plug connectors must be kept clean. The same mechanical protection regulations that apply to copper cables also apply to optical fiber cables. However, special attention should be paid to the bending radius and tensile strength of optical fiber cables.

1.1.3 Redundant PROFIBUS cables

Route redundant PROFIBUS cables on separate cable racks to avoid damage of both cables by a common cause.

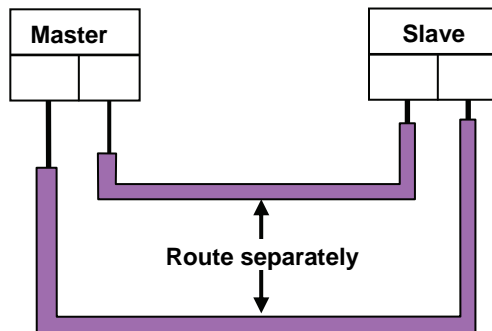

Fig. 3: Routing redundant PROFIBUS cables

1.2 Mechanical protection of PROFIBUS cables

Mechanical protective measures are intended to protect PROFIBUS cables against breakage or a short circuit of the cores or mechanical damage of sheath and shield.

! The measures for mechanical safety described here apply to electrical and optical cables alike!

- Route the PROFIBUS cable in a protective plastic pipe if you route the PROFIBUS cable away from cable racks.

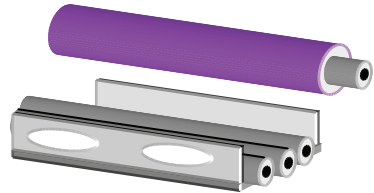

- In areas with heavy mechanical stresses, route the PROFIBUS cables in high-strength metal conduits. Hard PVC conduits may be used in areas with lower mechanical stresses.

- In case of 90° bends and building joints (e.g. expansion joints), the protective pipe may be interrupted. It must be ensured that the PROFIBUS cable cannot be damaged, e.g. by falling objects.

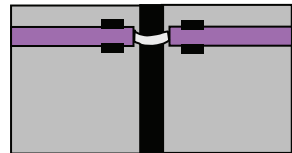

- In areas where people may step or vehicles pass, route the PROFIBUS cables in high-strength conduits or metal cable trays.

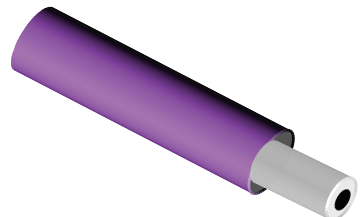

! Additional information about routing PROFIBUS cables outside of buildings, particularly in the ground, can be found in chapter 1.1.

1.3 Laying the cable

1.3.1 Electrical PROFIBUS cables

General

PROFIBUS cables can only handle limited mechanical loading. In particular, the cables can be damaged by excessive tension or pressure during installation. Twisting or excessive bending (kinking) of the PROFIBUS cable has the same effect. The following notes will help you avoid damage when laying PROFIBUS cables.



Replace PROFIBUS cables that were overstressed or damaged during laying.

Storage and transport

- During transport, storage and laying, the PROFIBUS cable must be closed with a shrink cap at both ends. This prevents an oxidation of the individual cores and any accumulation of moisture and dirt within the PROFIBUS cable.

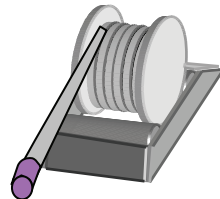

Temperature

- The manufacturer specifies minimum and maximum temperatures for PROFIBUS cable. The cable must be kept within these limits otherwise it may not meet the required mechanical and electrical specifications. The cable must be routed to avoid areas where the temperature is outside the specified limits.
- The temperature values can be found on the manufacturer's data sheets. Some manufacturers print temperature data on the cable sheath.
- The temperature range for PROFIBUS cable typically lies between $-40\text{ }^{\circ}\text{C}$ and $+60\text{ }^{\circ}\text{C}$. Caution: For some PROFIBUS cable types, the lower temperature limit is $-25\text{ }^{\circ}\text{C}$!

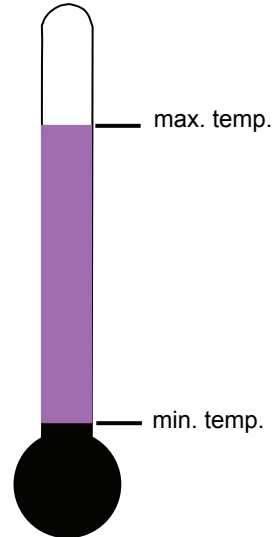

Tensile strength



The manufacturer specifies a maximum tensile strength for every cable type. Exceeding the maximum tensile strength damages or destroys the PROFIBUS cable. This is of particular importance in drag chains and garland suspensions due to the high mechanical load. Ensure that you choose the right type of cable for your application:

- PROFIBUS standard cable
 - PROFIBUS trailing cable
 - PROFIBUS festoon cable
-
- Pull the PROFIBUS cable by hand only.
Do not apply force when pulling.

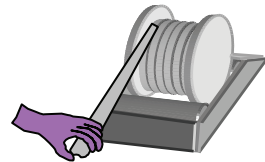

OK

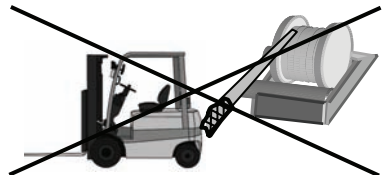

No

- Consider using rollers, for example, to provide strain relief when laying PROFIBUS cables.

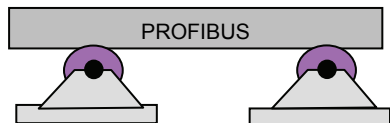

Pulling PROFIBUS cables with cable grips, protecting connectors

- Use cable grips for pulling PROFIBUS cables. If you have already assembled the PROFIBUS cable, you must protect the connector against mechanical load before attaching the cable grip. This can be achieved by placing a protective pipe over the connector.

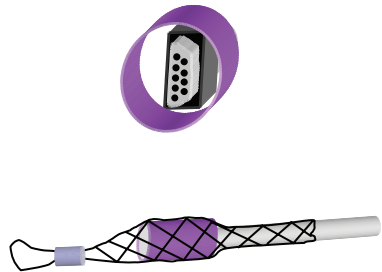

Strain relief

- Attach a strain relief to all cables that are subject to a tensile load at a distance of approximately 1 m from the connection point. The shield area at the cabinet entry is not sufficient for strain relief! Appropriate strain relief fittings are available from several manufacturers.

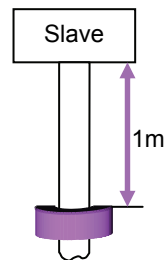

Compression loads

- Do not squash the PROFIBUS cable, e.g. by stepping on it or driving over it.
- In addition, avoid excessive stress or pressure on PROFIBUS cables, e.g. through pinching or squashing.



Twisting (torsion)

- Twisting the PROFIBUS cable can cause the individual cable elements to unwind. This, in turn, leads to a deterioration of the electrical characteristics and poor EMC performance. For this reason, do not twist the PROFIBUS cable. If twisting cannot be avoided, you must use torsion-proof PROFIBUS cables.

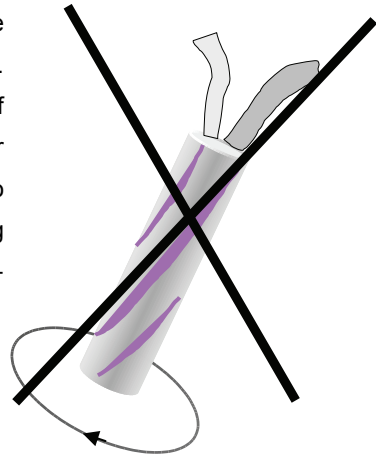

Trailing and garland cables

- Use only cables and corresponding suspension components approved by the manufacturer for trailing and garland cables. The correct cables and parts are available from various manufacturers.
- Ensure that trailing and garland cable are not damaged or pinched by structural components or other cables when in motion.

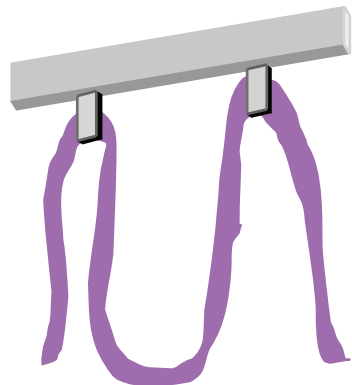

- Ensure that the cables are not crossed between festoon suspensions, since this can cause stretching or stress on the cable. Use separate suspensions for each cable.
- The chosen cable route must avoid any cable twisting. Twisting a PROFIBUS cable can lead to mechanical damage and poor EMC performance.

Flexible PROFIBUS cables

- For frequently twisted PROFIBUS cables (for example as used in robots) use flexible, torsion-proof PROFIBUS cables.

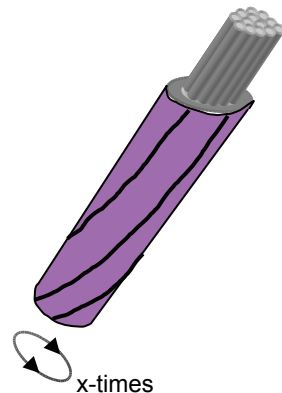

Maintaining bending radius

- Always maintain the minimum permissible cable bend radius. Dropping below the minimum bending radius leads to damage of the PROFIBUS cable and changing of its electrical properties. The minimum bend radius can be found on the manufacturer's data sheets.

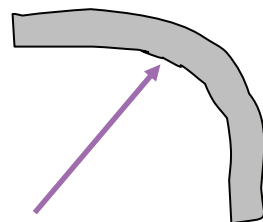

Observe minimum bending radius!

- For a simple bend, the radius should typically not be less than 10 times the cable diameter. If repeated bending is expected during service, for example due to attaching and detaching PROFIBUS stations, a larger bend radius is required (typically approximately 20 times the cable diameter).
- During laying, the PROFIBUS cable is mechanically subjected to additional tensile forces. For this reason, a larger bend radius must be maintained during pull-in than when in its final position. Pulling PROFIBUS cable around a corner is a particular problem. For this reason, you must use pulleys to avoid any excessive stress and sharp bends when pulling PROFIBUS cables around corners.
- The specified bend radius for flat PROFIBUS cables applies only to bending on the flat side. Bending such cables sideways requires a significantly larger bend radius.

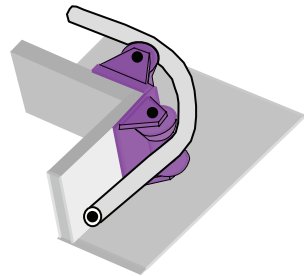

Avoid looping

- Pull the PROFIBUS cable straight off the drum, which should be free to rotate. Never unwind cable from a stationary drum.

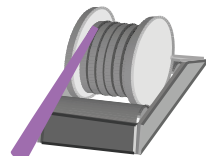

Use auxiliary equipment, such as drum feeders or rotary plates for this purpose. This prevents the formation of loops and associated cable kinking. In addition, it prevents the PROFIBUS cable from being twisted.

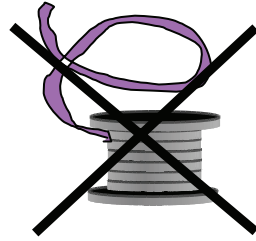

- If a loop should have occurred, wind the loop out of the PROFIBUS cable. Do not simply pull the PROFIBUS cable straight since this would stretch and twist the PROFIBUS cable. Since the copper core and the insulation behave differently under tension, the plastic may contract leading to non-insulated cores and creating a short circuit.

Avoid sharp edges

- Sharp edges can lead to PROFIBUS cable damage. For this reason, remove sharp edges and burrs with a file or a triangular scraper. This includes cut edges on cable trays.
- Protect edges at the end and corners with edge protection strip.

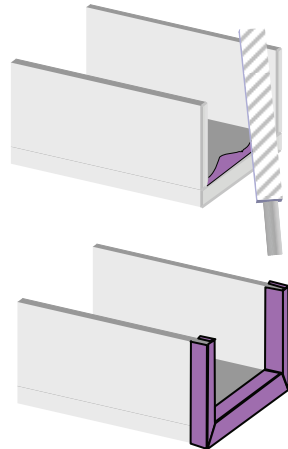

Considerations after installation

If additional cables are routed, you should ensure that previously laid PROFIBUS cables or other system cables are not overstressed or damaged. This can occur, for example, if the PROFIBUS cables are routed together with other cables on a common cable tray (if the electrical safety permits it). Special care should be exercised when rerouting new cables (for repairs or expansion). Pulling several cables into an existing cable run can damage the previously run cables.

Pull in the PROFIBUS cable last if you are laying it in a cable tray together with other cables.

1.3.2 Laying of optical fiber cables

General

PROFIBUS cables can only handle limited mechanical loading. In particular, the cables can be damaged by excessive tension or pressure during installation. Twisting or excessive bending (kinking) of the PROFIBUS cable has the same effect. The following notes will help you avoid damage when laying PROFIBUS cables.

- ! Replace PROFIBUS cables that were overstressed or damaged during laying.

Storage and transport

- During transport, storage and laying, the PROFIBUS cable must be closed with a shrink cap at both ends. This prevents any accumulation of moisture and dirt within the PROFIBUS cable.

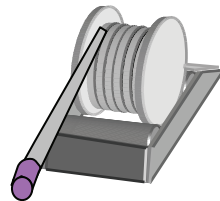

Temperature

- The manufacturer specifies minimum and maximum temperatures for PROFIBUS cable. The cable must be kept within these limits otherwise it may not meet the required mechanical and optical specifications. The cable must be routed to avoid areas where the temperature is outside the specified limits.
- The temperature values can be found on the manufacturer's data sheets. Some manufacturers print temperature data on the cable sheath.
- The temperature range for PROFIBUS cable typically lies between $-5\text{ }^{\circ}\text{C}$ and $+50\text{ }^{\circ}\text{C}$.

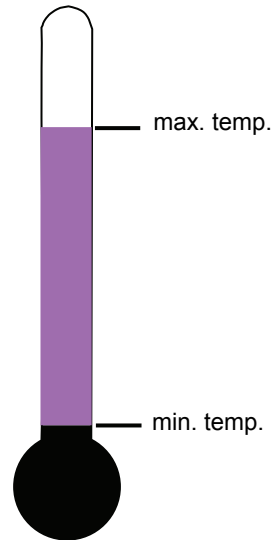

Tensile strength



The manufacturer specifies a maximum tensile strength for every cable type. Exceeding the maximum tensile strength damages or destroys the PROFIBUS cable. This is of particular importance in drag chains and garland suspensions due to the high mechanical load. Ensure that you choose the right type of cable for your application:

- PROFIBUS standard cable
- PROFIBUS trailing cable
- PROFIBUS festoon cable

- Pull the PROFIBUS cable by hand only.
Do not apply force when pulling.

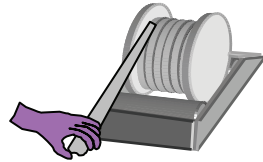

OK

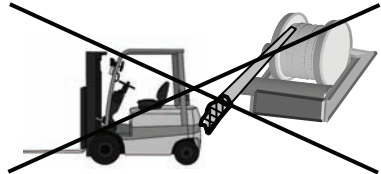

No

- Consider using rollers, for example, to provide strain relief when laying PROFIBUS cables.

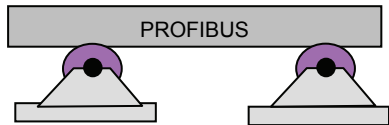

Protect the connectors from dirt

- Optical fiber connectors are sensitive to dirt.
- Protect unconnected plugs and sockets by fitting the supplied dust-protection caps.

Mechanical load of optical fiber cable



Optical fiber cables are particularly sensitive to mechanical loads.
Exercise extra caution when laying optical fiber cables.

Observe the following instructions:

- Do not twist the optical fiber cable.

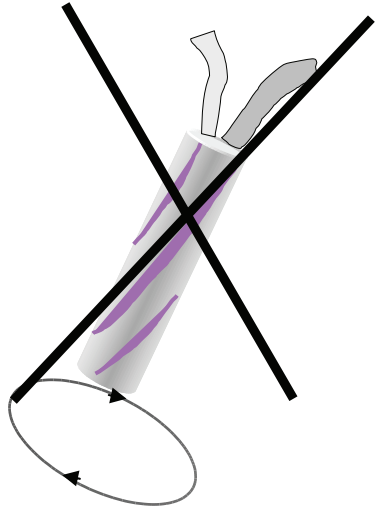

-
- Do not pinch the optical fiber cable.



- Observe the permissible tensile forces.
Do not overstretch the optical fiber cable.

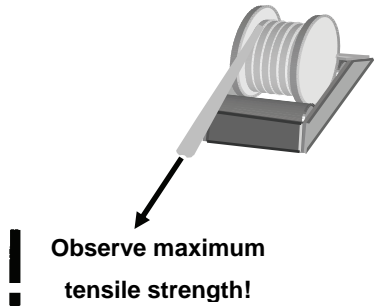

- Observe the minimum bend radius.

Use pulling supports, protect connectors

- Use suitable pulling supports for pulling in optical fiber cables. Some manufacturers supply the correct pulling support with the optical fiber cable. If no pulling support is supplied, ask the cable manufacturer for the appropriate pulling support.



- Protect pre-assembled plug connections against damage and dirt. A cable conduit can be used for this purpose. Pad any cavities.

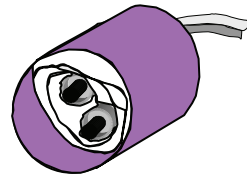

- Ensure that the dust-protection caps are fitted.

Attaching the strain relief

- Some plug connections for optical fiber cables feature their own strain relief. Nevertheless, attach an additional strain relief as close as possible to the PROFIBUS station.

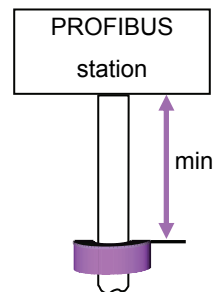

Maintaining bending radius

- Always maintain the minimum permissible cable bend radius. Dropping below the minimum bending radius leads to damage of the PROFIBUS cable and changing of its optical properties. The minimum bend radius can be found on the manufacturer's data sheets.

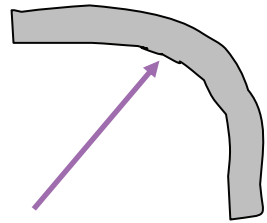

Observe minimum bending radius!

- During laying, the PROFIBUS cable is mechanically subjected to additional tensile forces. For this reason, a larger bend radius must be maintained during pull-in than when in its final position. Pulling PROFIBUS cable around a corner is a particular problem. For this reason, you must use pulleys to avoid any excessive stress and sharp bends when pulling PROFIBUS cables around corners.
- The specified bend radius for flat PROFIBUS cables applies only to bending on the flat side. Bending such cables sideways requires a significantly larger bend radius.

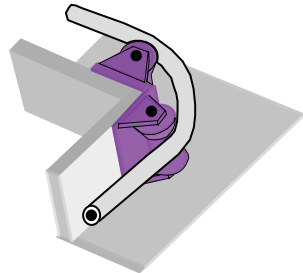

Avoid looping

- Pull the PROFIBUS cable straight off the drum, which should be free to rotate. Never unwind cable from a stationary drum.

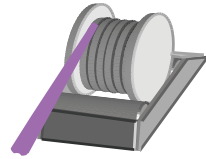

- Use auxiliary equipment, such as drum feeders or rotary plates for this purpose. This prevents the formation of loops and associated cable kinking. In addition, it prevents the PROFIBUS cable from being twisted.



- If a loop should have occurred, wind the loop out of the PROFIBUS cable. Do not simply pull the PROFIBUS cable straight since this would damage the optical PROFIBUS cable.

Avoid sharp edges

- Sharp edges can lead to PROFIBUS cable damage. For this reason, remove sharp edges and burrs with a file or a triangular scraper. This includes cut edges on cable trays.
- Protect edges at the end and corners with edge protection strip.

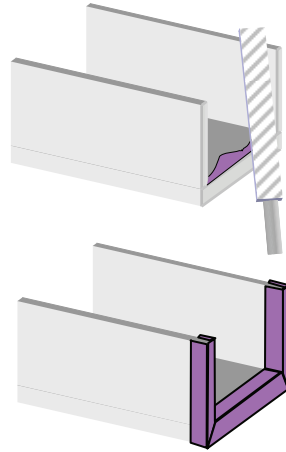

EMC interference

Optical fibers are not susceptible to EMC interference (electrical pickup). For this reason, optical fiber cables can be routed together with any copper cables, even power cables.

Considerations after installation

If additional cables are routed, you should ensure that previously laid PROFIBUS cables or other system cables are not overstressed or damaged. This can occur, for example, if the PROFIBUS cables are routed together with other cables on a common cable tray (if the electrical safety permits it). Special care should be exercised when rerouting new cables (for repairs or expansion). Pulling several cables into an existing cable run can damage the previously run cables.

Pull in the PROFIBUS cable last if you are laying it in a cable tray together with other cables.

2 Assembling PROFIBUS cables

2.1 PROFIBUS termination

For a good signal transmission it is necessary to terminate PROFIBUS segments by a bus termination. For PROFIBUS RS 485 a bus termination consists of a combination of three resistors. For PROFIBUS MBP (PA) a bus termination consists of a resistor and a capacitor.

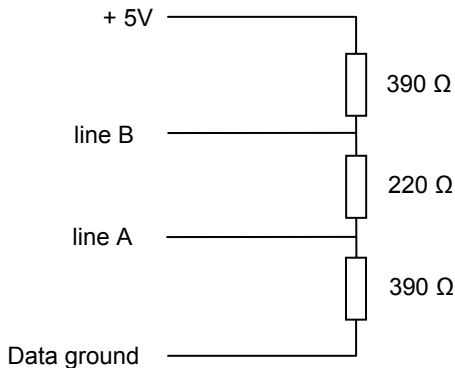

Fig. 4: Bus termination PROFIBUS RS 485

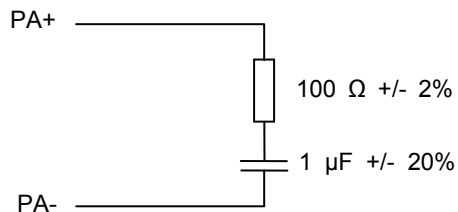

Fig. 5: Bus termination PROFIBUS MBP (PA)

Bus terminations are available in different forms.

- Bus termination built into a connector
- Bus termination built into a PROFIBUS-device
- ...

Bus terminations that are built into PROFIBUS-devices or into PROFIBUS connectors can often be switched on or off. Because of this it can easily happen that too many bus terminations are used in a PROFIBUS segment. Therefore you must observe that PROFIBUS segments are only terminated at the two segment ends and nowhere else. Any additional terminations can cause corruption of the PROFIBUS signals and network malfunction.

In 9-pin Sub-D-connectors the switch for the bus termination often has a second function of isolating the “outgoing” cable from the connector. It is essential, therefore, that only the “incoming” cable entry is used on connectors located at the ends of a PROFIBUS segment. In such situations only one PROFIBUS cable is connected and the bus termination is switched on. If the incorrect cable entry is inadvertently used at such connectors, neither the PROFIBUS-device nor the termination network will be connected to the segment. Most connectors mark the incoming and outgoing cable entries with arrows.

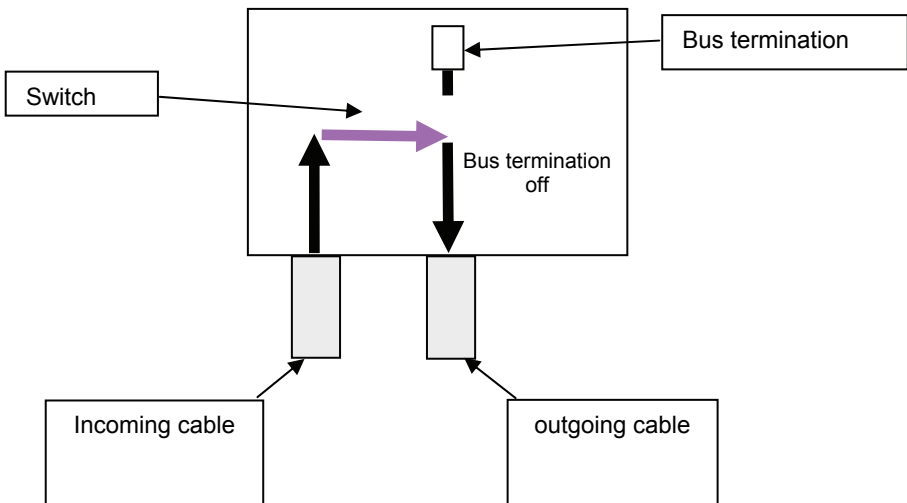

Fig. 6: termination on / incoming and outgoing cable not connected

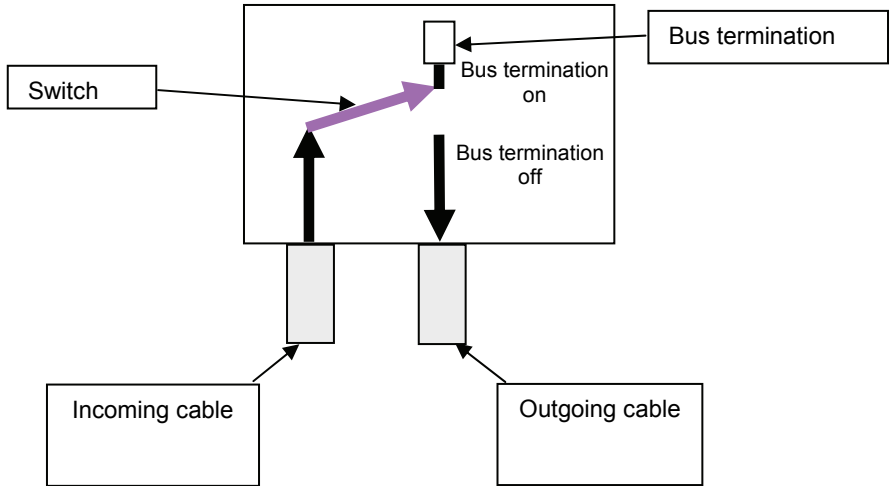
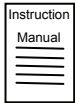

Fig. 7: Bus termination off / incoming cable and outgoing cable connected



Read the manufacturer's instructions. Where available, these instructions may provide important information about the use of built-in bus terminations.

2.2 Assembling connectors

Several types of connector are available to connect PROFIBUS copper cables to PROFIBUS stations.

The 9-pin Sub-D connector is used for the area inside control cabinets. Outside control cabinets, the M-12 or the hybrid connector can be used. The PROFIBUS station determines the type of connector that is used.

Different connectors require different wiring techniques; therefore it is not possible to provide general instructions for assembling plug connections. The types of connectors most frequently used are: The 9-pin Sub-D connector and the 5-pin M-12 connector (3 contacts assigned) for PROFIBUS-RS 485 and the 4-pin M-12 connector for PROFIBUS-MBP (PA) (PROFIBUS-PA). The hybrid connector is also available for PROFIBUS-DP.

You should also always observe the instructions of the connector manufacturer in addition to the following assembly examples.



The type of connector is determined by the PROFIBUS station socket type. The PROFIBUS devices should be selected with this in-mind. Ensure that device connectors meet your requirements for the environment in which they are used.

2.2.1 9-pin Sub-D connection

The 9-pin Sub-D connector is suitable for use inside control cabinets (IP 20). Unless using pre-made cable assemblies, the connector must be fitted to the PROFIBUS cable.

The PROFIBUS cables are normally daisy-chained through the connector. This allows PROFIBUS station connection without using T-junctions (which introduce spur lines). For this reason, PROFIBUS connectors normally have two cable entries, each with a set of terminals. Each set of terminals is normally labeled “A” and “B” or given a color reference, e.g. “green” and “red”. These two terminals connect to the two data wires in the PROFIBUS cable. The color scheme must be used consistently within a segment; i.e. the cores must not be swapped over. The

PROFIBUS guideline Interconnection Technology specifies the following assignment:

- A: green
- B: red

Wiring techniques differ from manufacturer to manufacturer; these can be divided into two groups: preassembled PROFIBUS cables and field-assembled PROFIBUS cables. The wiring techniques for pre-assembled PROFIBUS cables require special tools. For this reason, you should always select a method that can be field-assembled for on-site installation. This also offers the benefit that the PROFIBUS cable can be easily reconnected in case of repair or maintenance.

For field assembled PROFIBUS cables the following technologies are used:

- a. Screw methods
- b. Insulation displacement methods
- c. Cage clamp method

The following sections provide examples of a few implemented solutions from different manufacturers. However, they do not provide full assembly instructions. You should always refer to the specific manufacturer's instructions.

Ensure that you are only using PROFIBUS cables approved by the connector manufacturer for use with the respective connector. This applies particularly to the use of insulation displacement technology.



At least one of the PROFIBUS connectors should have a socket for a programming or diagnostic device (piggy-back socket) which is best located at the beginning or the end of the cable (segment).



Use only Sub-D-connectors that ensures a good conducting of the shield with the connector by some grooves.

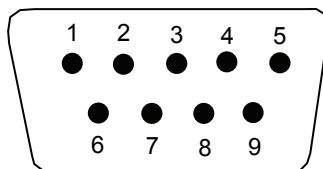

Pin	Signal	Description		Specification
		Cable	Device	
1	(Shield)	Shield or potential equalization		Not recommended
2	M24		Ground of 24V power supply	Optional ^b
3	RxD/TxD-P	Receive/Transmit data; line B (red)		Mandatory
4	CNTR-P		Control of repeater direction	Optional ^b
5	DGND		Data ground (reference voltage to VP)	Mandatory
6	VP ^a		Power supply +5v (e.g. for bus termination)	Mandatory
7	P24		+24V power supply	Optional ^b
8	RxD/TxD-N	Receive/Transmit data; line A (green)		Mandatory
9	CNTR-N		Control of repeater direction	Optional ^b

^a Minimum current capability is 10mA
^b These signals should be provided by the device if converters from RS485 to fibre optic transmission are to be supported

Fig. 8: pin assignment of 9-pin Sub-D-connector front side

Screw terminals

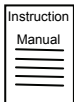

Read the manufacturer's instructions, these instructions may provide important information about the connector design and use. The following description shows the assembly process in general. It does not replace the detailed instruction of the manufacturer.

The typical steps listed below may be followed:

- Open the connector.

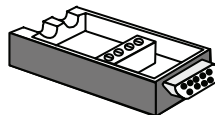

- Strip the PROFIBUS cable insulation.

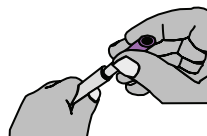
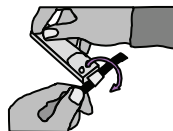

- Ensure that the stripped cable dimensions are correct for the connector you are using.

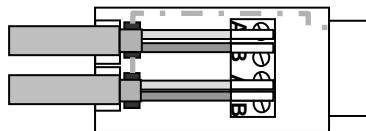

- Strip the insulation from the cores.



- Insert the cores in the opened screw terminals. Ensure that a good connection is made between the cable shield and the connector shield. Observe the marking for the incoming and outgoing cables.

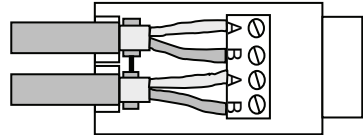

- Using an appropriately sized screwdriver, screw the terminals to grip the stripped cable cores (observe the torque).

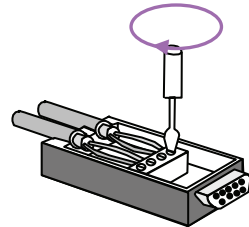

- Check the cable shield connection and ensure that there is no contact between the shield and the cores.

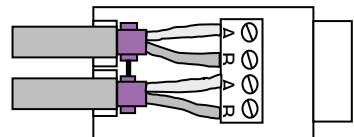

OK

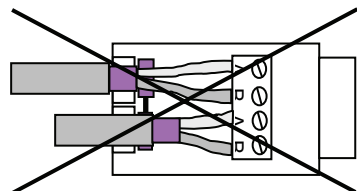

No

- Fasten the strain relief clamp.

- Close the connector casing.

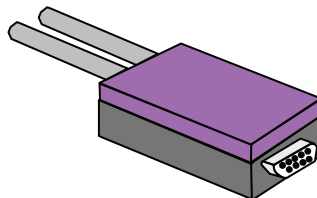

- Ensure that, where provided, the termination switch is correctly set. The termination should be switched on at both ends of the PROFIBUS segment and nowhere else.

To ensure proper transmission and protection from interference, observe the following points:

1. Route the cores inside the connector without kinking.
2. The connection between the connector shield and the PROFIBUS cable shield must have a large surface area.
3. The cable must not be pinched by the strain relief.

■ Some connector types have an integrated bus termination with outgoing cable isolation. Additional information about isolating connectors can be found in chapter 2.1. In such cases, always read the manufacturer's information.

Insulation displacement method

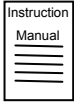

Read the manufacturer's instructions, these instructions may provide important information about the connector design and use.

The major advantage of the insulation displacement method lies in simplifying and speeding up the cable connection.

■ The insulation displacement method generally consists of a matched system of connector, PROFIBUS cable and wire stripper. Use only components that are designed to work together as described in the manufacturer's instructions, otherwise problems may occur.

■ When using the insulation displacement method, the cable end must be cut off for every connection (e.g. when changing connectors). Never re-use the cable-ends without cutting them off after a connector has been removed, otherwise a poor contact may result.

- Open the connector

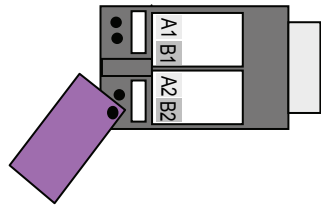

- Strip the insulation from the cable. Cores and shielding should be stripped to the specified length (observe the connector manufacturer's instructions). Note that the individual cores should not be stripped of insulation with this type of connector.

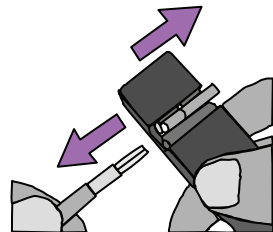

Assembling PROFIBUS cables

- Insert the cores fully into the opened contact block. Observe the marking for the incoming and outgoing cables.

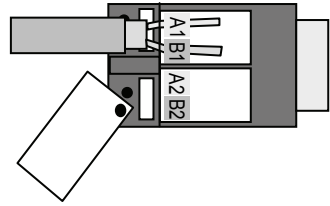

- Close the contact blocks.

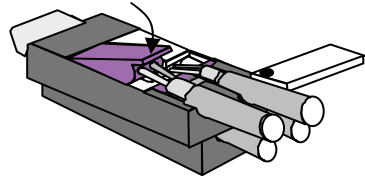

- Ensure that a good connection is made between the cable shield and the connector shield connection. Ensure that there is no contact between the shielding and the cores.

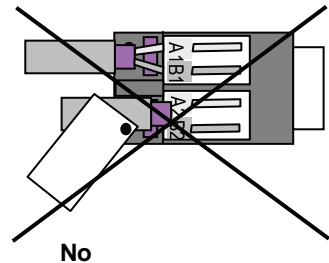
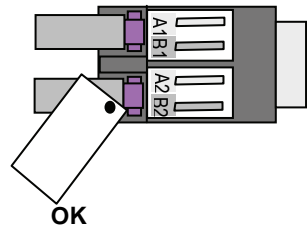

- Close the connector and fasten the strain relief.

Wire stripping tools are normally available for insulation displacement technology that matches the manufacturer's connectors and cables. These tools significantly simplify and speed-up the connection.

Some cable stripping tools can be fitted with different cutter cassettes for stripping shielded cables with different geometry. Please ensure that the stripping tool has the correct cutter cassette for the PROFIBUS cable/connector system being used.

2.2.2 M-12 plug connections

RS 485 connectors

The 5-pin M-12 connector is another type of connector for PROFIBUS-RS 485 devices where extreme industrial environments exist.

Only shielded connectors are used for PROFIBUS. The connectors feature a mechanical key (B-coding). The following variant of the M-12 connector is used for PROFIBUS-RS 485.

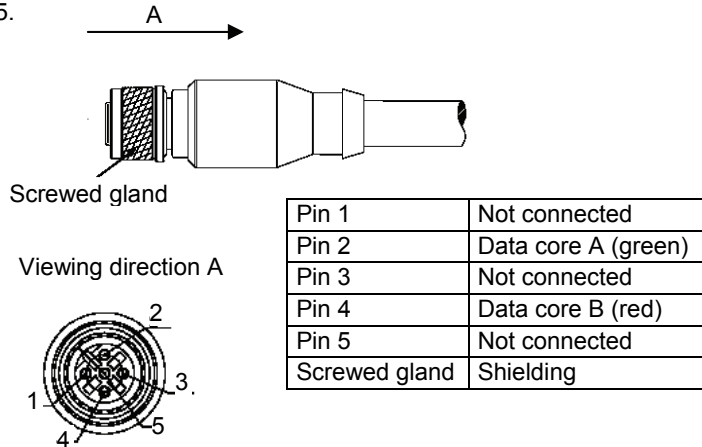
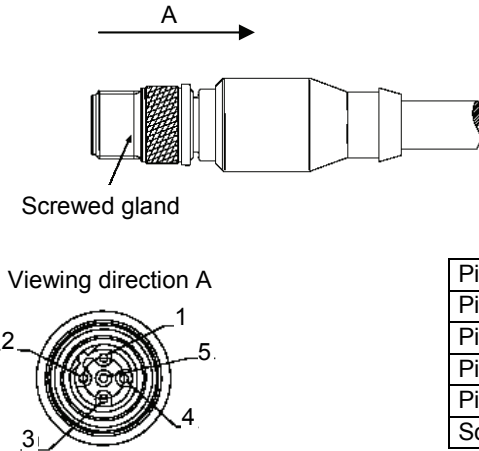

Fig. 9: 5-pin M-12 female socket (PROFIBUS-RS 485)

Pins 1 and 3 are used by PROFIBUS stations to provide a supply for a termination network. Pin 5 may be connected to shielding (not recommended).



Pin1	Not connected
Pin 2	Data core A (green)
Pin 3	Not connected
Pin 4	Data core B (red)
Pin 5	Not connected
Screwed gland	Shielding

Fig. 10: 5 pin M-12 male plug for RS 485

Pin 5 may be connected to shielding (not recommended)

MBP (PA) connectors

The 4-pin M12 connector is used for PROFIBUS-MBP (PA). Three of the four contacts are used. The following variant of the M-12 connector (A-coding) is used for the PROFIBUS-MBP (PA).

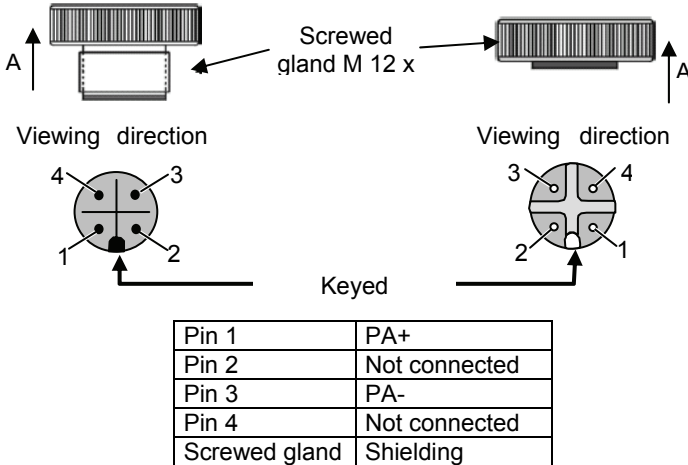

Fig. 11: 4-pin M-12 connector (for MBP (PA)) – male plug (left) and female socket (right)

M-12 connectors are suited for use outside of control cabinets (IP 65/67). One side of the connector is permanently installed in the PROFIBUS station and the other connector is connected to the cable.

In many applications, the installation can be simplified by using preassembled PROFIBUS cables. These PROFIBUS cables are available ready-tested and in different lengths.

Tee units are available for M-12 connectors to connect PROFIBUS cable segments. For PROFIBUS-MBP (PA), the PROFIBUS stations are generally connected via tee units. For PROFIBUS-RS 485, tee units are available as options. Special Tee units containing decoupling circuits need to be used for baud rates from 3 to 12 MBaud.



Read the manufacturer's instructions. Where available, these instructions may provide important information about the tee units.

The connections of the M-12 connector feature the contact positions as shown in Fig. 11.

Some M-12 connectors label the pins “A” and “B” or give a color reference e.g. “green” and “red”. These two pins connect to the two data wires in the PROFIBUS cable. The color scheme must be used consistently within a segment; i.e. the cores must not be swapped over. The PROFIBUS guideline Interconnection Technology specifies the following assignment:

A: green
B: red

Wiring techniques differ from manufacturer to manufacturer; these can be divided into two groups: preassembled PROFIBUS cables and field-assembled PROFIBUS cables. The wiring techniques for pre-assembled PROFIBUS cables require special tools. For this reason, you should always select a method that can be field-assembled for on-site installation. This also offers the benefit that the PROFIBUS cable can be easily reconnected in case of repair or maintenance.

For field assembled cables the following technologies are used:

- a. Screw methods
- b. Insulation displacement methods
- c. Cage clamp technology

The wiring techniques for the pre-assembled PROFIBUS cables require special tools. For this reason, you should always select a method that can be field-assembled for an on-site installation. This also offers the benefit that the PROFIBUS cable can be reconnected in case of repair or maintenance.

The following sections provide examples of a few implemented solutions from different manufacturers. However, they do not provide full assembly instructions. You should always refer to the specific manufacturer’s instructions.

Ensure that you are only using PROFIBUS cables approved by the connector manufacturer for use with the respective connector. This applies particularly to the use of insulation displacement technology. In addition, ensure that the conductor

diameter matches the connector housing for IP 65 applications. Only then is a correct seal between the connector and cable ensured.

For M-12 connectors, there are several methods for establishing the bus termination. These are:

- Use of termination connectors
- Termination integrated in the tee unit
- Termination integrated in the device

Note that the PROFIBUS segment must be terminated at each end using one of the listed methods.

Screw terminals

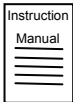

Read the manufacturer's instructions these instructions may provide important information about the connector design and use.



IP 67 connectors generally consist of several parts. Open the package and ensure that all parts are available.

The typical steps listed below may be followed:

- Open the connector.

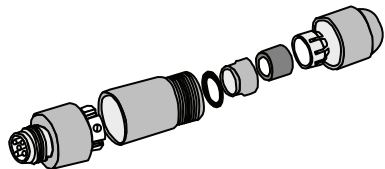

Assembling PROFIBUS cables

- Pass the cable through the screwed gland and any other parts of the connector housing that are required.

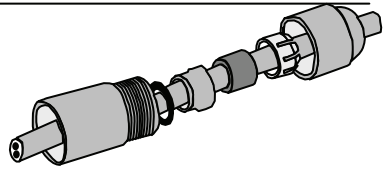

- Strip the PROFIBUS cable insulation; ensure that the stripped cable dimensions are applicable to the connector you are using.

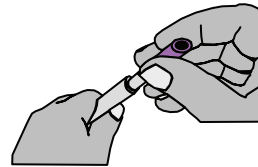
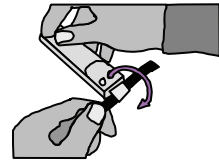

- Strip the insulation from the cores.



- Insert the cores into the opened contact block.

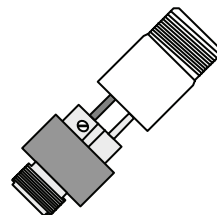

- Using an appropriately sized screwdriver, screw the terminals to grip the stripped cable cores (observe the torque).

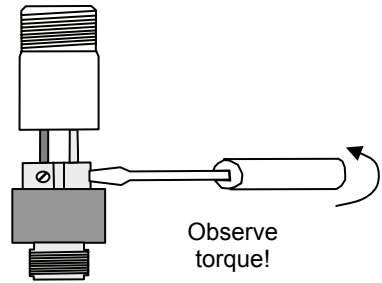

- Connect the cable shield to the connector housing. For this the shield is normally folded back over the cable to make a good contact. Place the seal ring in the bush and push into the connector housing to grip the cable shield. Ensure that there is no contact between the shield and the cores.

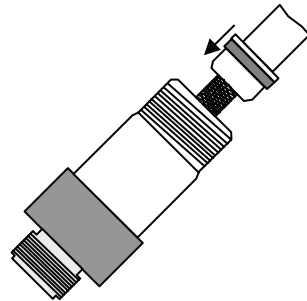

- Fasten the screwed gland to provide cable strain relief and seal the connector.

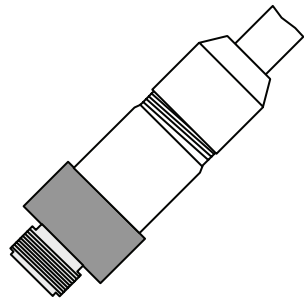

Insulation displacement method

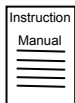

Read the manufacturer's instructions these instructions may provide important information about the connector design and use.

The major advantage of the insulation displacement method lies in simplifying and speeding up the cable connection.

■ The insulation displacement method generally consists of a matched system of connector, PROFIBUS cable and wire stripper. Use only components that are designed to work together as described in the manufacturer's instructions, otherwise problems may occur.

■ When using the insulation displacement method, the cable end must be cut off for every connection (e.g. when changing connectors). Never re-use the cable-ends without cutting them off after a connector has been removed, otherwise a poor contact may result.

The basic steps are as follows:

- Open the connector

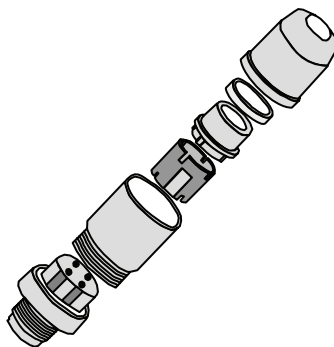

- Pass the cable through the screwed gland and any other parts of the connector that are required.

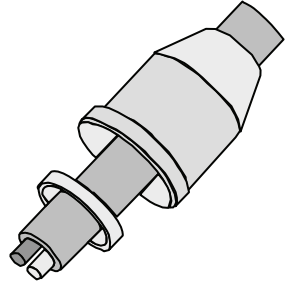

- Strip the insulation from the cable; ensure that the stripped cable dimensions are applicable to the connector you are using (observe the connector manufacturer's data).

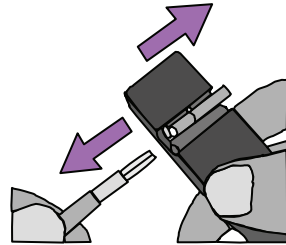

- Connect the shield; ensure that there is no contact between the shielding and the cores.

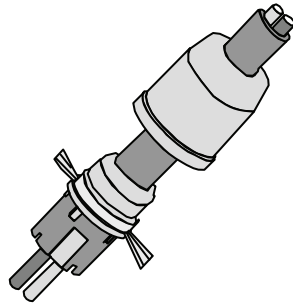

- Insert the cores in the opened contact block.
-

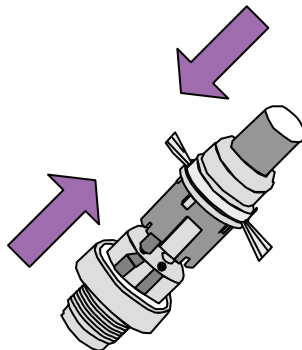

- Close the contact block.

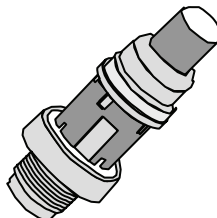

- Close the connector housing and screwed gland to provide strain relief on the cable and seal the connector.

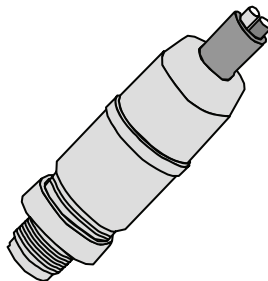

Manufacturers often supply wire strippers that match their insulation displacement connectors. Such tools significantly speed up and simplify the connection procedure.



Wire strippers can be adapted for different shielded cables by using different cutter cassettes. Ensure that the cutter cassette being used is correct for your cable/connector system.

2.2.3 Hybrid connectors

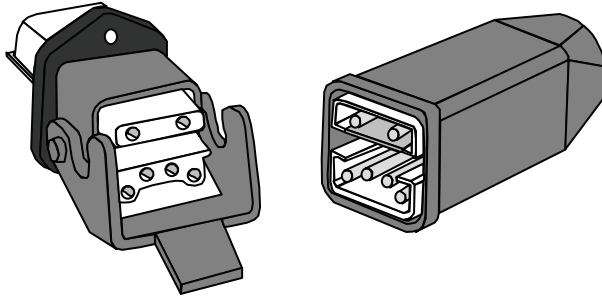

Hybrid connectors simplify installation of PROFIBUS stations by wiring the voltage supply and the PROFIBUS cable in a single connector. Preassembled cables, which are available in different lengths from the cable manufacturers, provide a particularly simple solution.

When it is necessary to assemble hybrid connectors on site, the manufacturer's instructions must be followed. The contacts of the hybrid plug are generally crimped. Only suitable crimping tools should be used; these are generally available from the connector manufacturer. Only correctly crimped connections ensure a permanent, high-quality connection.

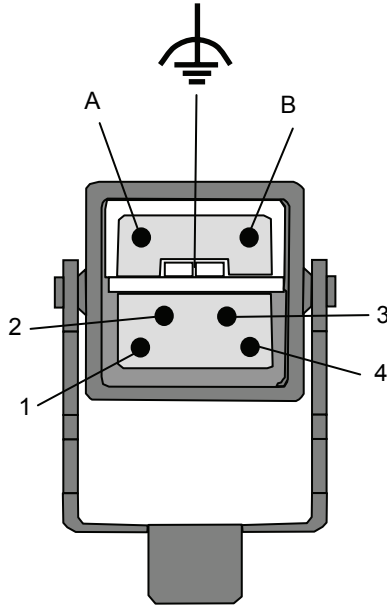

Pin	Usage	Comment
1	+24 V DC	Not Switched
2	Ground (0 V)	Ground for Pin 1
3	Ground (0 V)	Ground for Pin 4
4	+24 V DC	Switched
A	Line A	
B	Line B	

Fig. 12: Pin assignment for Hybrid connector by Desina

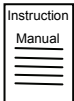

Read the manufacturer's instructions, these instructions may provide important information about the connector design and use.

The general steps to assemble such a connector are as follows:

! IP 67 connectors generally consist of several parts. Open the package and ensure that all parts are available.

- Open the connector

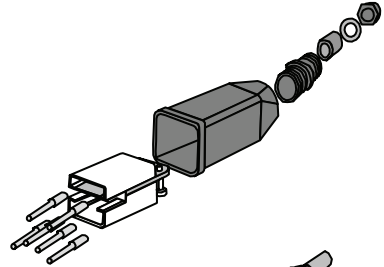

- Pass the cable through the screwed gland and any other parts of the connector that are required.

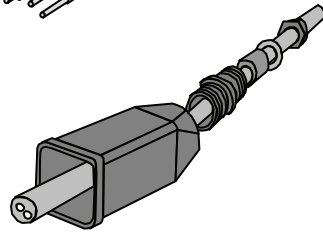

- Strip the insulation from the cable; ensure that the stripped cable dimensions are applicable to the connector you are using (observe the manufacturer's data).

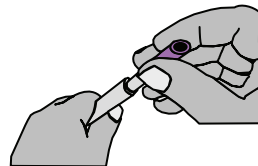
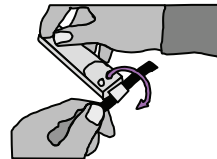

Assembling PROFIBUS cables

- Strip the insulation from the cores



- Crimp the contacts onto the cable cores.

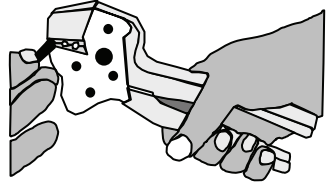

- Insert the contacts in the appropriate connector block openings.

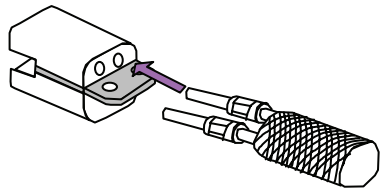

- Connect the cable shield.

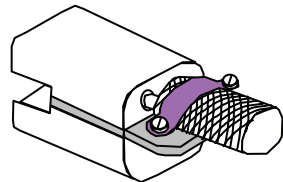

- Close the connector and fasten the screwed gland to provide strain relief.

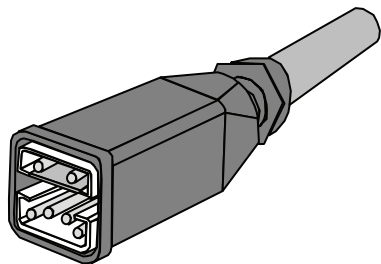

2.3 Direct connection of PROFIBUS stations

Some PROFIBUS stations provide direct connection to the PROFIBUS cable. The connection methods used are similar to those for installing cable into connectors, for example, screw terminals or insulation displacement connection. However, the design of the connections differs greatly. Always use the manufacturer's instructions if available. The following section provides only typical installation instructions.

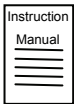

Read the manufacturer's instructions. Where available, these instructions may provide important information on how to connect the PROFIBUS cable to the device.

The general steps are as follows:

- Strip the PROFIBUS cable insulation; ensure that the stripped cable dimensions are applicable to the device.

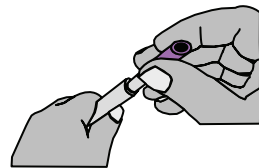
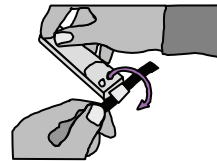

- Strip the insulation from the cores.



- Insert the cores in the contact openings according to the core assignment (A=green, B=red).

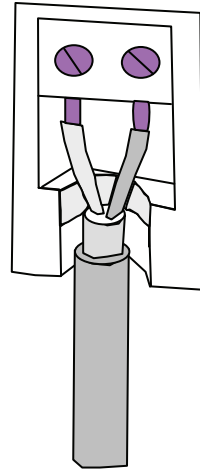

- Using an appropriately sized screwdriver, screw the terminals to grip the stripped cable cores (observe the torque).

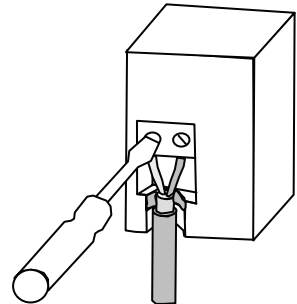

- Ensure that a good connection is made between the cable shield and the device shield connection. Ensure that there is no contact between the shielding and the cores.

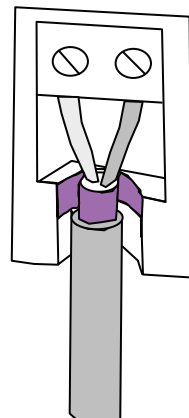

- Fasten the strain relief.

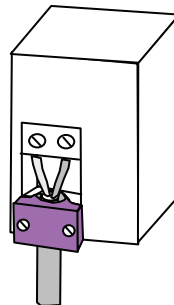

- Close the PROFIBUS station.

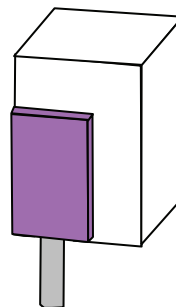

The direct connection of the PROFIBUS cable to a PROFIBUS station using the insulation displacement method is similar to the connection of a PROFIBUS station with screw terminals. However, the individual cores should not be stripped of insulation with the insulation displacement method of connection.

- The insulation displacement method generally consists of a matched system of PROFIBUS cable, wire stripper and connection components.
- Use only components that are designed to work together as described in the manufacturer's instructions, otherwise problems may occur.
- When using the insulation displacement method, the cable end must be cut off for every connection (e.g. when changing stations). Never re-use the already-fastened cable after a device has been removed, otherwise a poor contact may result.

2.4 Flexible PROFIBUS cables

The cores of flexible PROFIBUS cables consist of many fine strands. In general, stranded cores should be fitted with wire-end ferrules (boot-lace ferrules) to keep the strands together and prevent them shorting. In many cases, however, the screw terminals on PROFIBUS components are designed to directly accept stranded cable without wire-end ferrules. To determine whether the screw terminals can directly accept stranded cable without a ferrule, you should compare the terminals with the following two figures. However, you should always follow the terminal manufacturer's instructions.

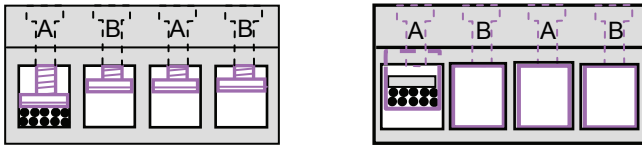

Fig. 13: Screw terminals – suitable for stranded cables without wire-end ferrules

However, terminals where only one screw pushes onto the core from the top are not allowed without wire-end ferrules.

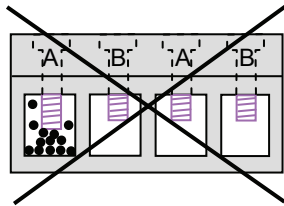
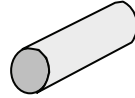

Fig. 14: Screw terminals – not suitable for stranded cables without wire-end ferrules

The following must be observed in the use of wire-end ferrules:

- It is best to use plated copper wire-end ferrules. Never use wire-end ferrules made from aluminum.



- Use wire-end ferrules that fit the cross section of the cores. Incorrectly fitting wire-end ferrules lead to a bad contact.

- Ensure that the length of the wire-end ferrules is completely filled. If the wires end before the end of the wire-end ferrules, additional insulation must be removed.

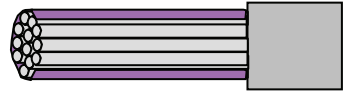

OK

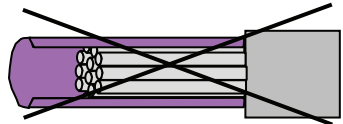

No

- Do not twist the strands before inserting into the wire-end ferrule. Leave the strands straight.

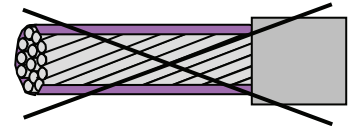

No

- Crimp the wire-end ferrules only with crimping pliers with positive lock. Positive lock means that the crimping pliers can only be opened if the wire-end ferrule was completely crimped.

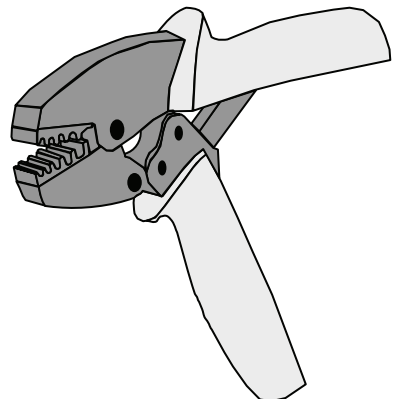

- Never use any other pliers or cutters for crimping. They do not exert sufficient crimping force. In this case, the contact between wire-end ferrule and core is insufficient. In addition, there is the risk of damaging the cores.

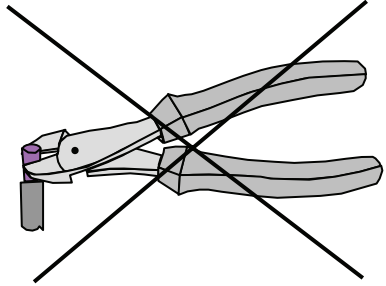

2.5 Assembling optical fiber cables

The optical fiber cables listed in Table 2 are standard for PROFIBUS.

Table 2: Optical fiber cables for PROFIBUS

Use for line lengths	Type of fiber	Fiber diameter Core/Sheath	Operating wavelength
up to 100m	Plastic Optical Fiber	980/1000 µm	650 nm
up to 500m	PCF or HCS fiber **1	200/230 µm	650 nm
up to 3km	Multimode fiber optic	50/125 µm 62.5/125 µm	860 nm
up to 15km	Single mode fiber optic	10/125 µm	1300 nm

*1 PCF and HCS are trademarks

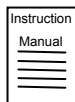

The technical data of the optical fiber components can be found on the manufacturer's data sheets.

Either Plastic Optical Fibers or PCFTM/HCSTM fibers can be used at the same optical interface. Multimode and single mode optical fibers each require their own interface design.

The required components for an optical path may be determined as follows:

1. Determine the length of the path to be covered

Determine the fiber type required for this path according to The optical fiber cables listed in 122H Table 2 are standard for PROFIBUS.

2. Select a suitable device for this fiber type
3. The device description shows which connector type fits the optical interface of the selected device.

The assembly of an optical fiber cable depends upon the fiber and connector type. In general, optical fiber cables with a smaller fiber diameter require a higher precision in assembly. Correspondingly, assembly tools will be more expensive.

2.5.1 Fiber Connectors for PROFIBUS

BFOC/2.5 connectors

PROFIBUS stations with an optical interface generally use connectors of type BFOC/2.5. This worldwide standardized connector is also offered under the product name “ST connector” by some manufacturers.



Fig. 15: BFOC/2.5 type connector (ST connector)

Other connector types

However, other connector types can also be found specifically for optical interfaces for plastic optical fiber. These connector types generally feature a simpler design than the BFOC/2.5 connector. The manufacturer’s instructions will show which connector type must be used. If in doubt, please contact the manufacturer of the PROFIBUS components.

2.5.2 Plastic optical fiber cable

Optical fibers made from plastic are relatively soft with a diameter of approximately 1mm. For this reason, they are well suited for field assembly. Many manufacturers offer specially developed connectors for field assembly. When used together with the appropriate assembly tools, such connectors allow untrained people to successfully assemble plastic optical fibers.

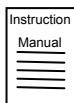

Read the manufacturer’s instructions. Where available, these instructions may provide important information.

The example shows the typical steps for assembling an ST connector.

- Strip the optical fiber cable insulation.

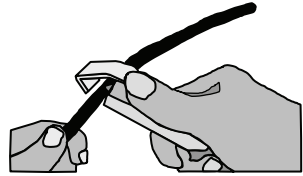

- Separate the optical fiber pair using a sharp knife (do not pull the fibers apart, because of the risk of fiber breakage)

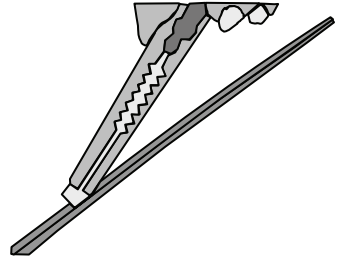

- Pass the optical fiber cable through the connector housing and any other parts that are required.

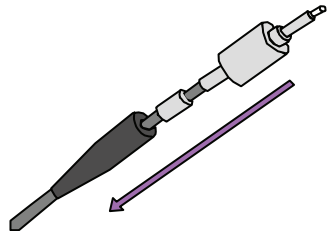

- Strip the optical fiber outer covering (Observe the correct stripping diameter! 1.5 mm for ST connectors)

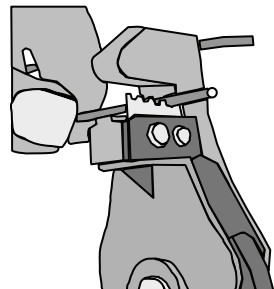

- Crimp the connector (use the correct crimping tool)

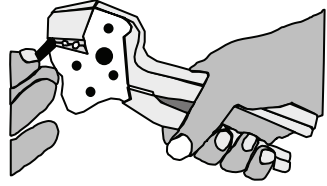

- Polish the end of the optical connector in two steps (coarse and then fine polish). Use a figure of 8 pattern during polishing.

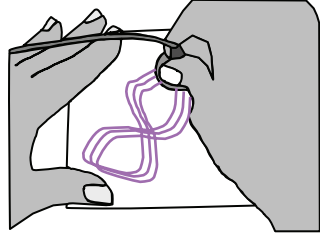

- Remove any abrasion

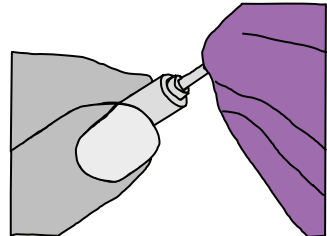

Do not plug the connector into the PROFIBUS component until the cable is completely assembled. The end of the optical fiber protruding from the connector could damage the optical interface.

2.5.3 Glass optical fiber cable

The assembly of glass optical fiber cables requires special tools. The tools are always matched to a specific connector type and can only be used with this type of connector. Many manufacturers offer “mounting kits” to help with cable and connector assembly.

The individual requirements dependent upon the fiber type being used:

PCF-/HCS™ optical fibers

- PCF-/HCS™ optical fibers incorporate a relatively coarse glass fiber are so are well suited for field assembly.
- Many manufacturers offer connectors specially developed for the field assembly.
- The necessary tool kits for assembly are available from the connector manufacturer.
- The operating steps depend upon the connector type and tools used. For this reason, follow the manufacturer's instructions pertaining to the tool and the connector. With a little training and practice connectors can be successfully assembled.

Glass optical fibers 50/125, 62.5/125 and 10/125

- The assembly of these fine fibers requires a high degree of precision that can only be accomplished with special tools.
- If you use glass optical fibers only occasionally, it is more cost-efficient to use preassembled cables. They are available in different lengths from the cable manufacturer.
- If you frequently have to assemble glass optical fibers, contact a connector manufacturer and ask for advice with respect to the connectors and tool kits being offered.



Do not leave behind any waste from assembling optical glass fiber cables. The fine fibers of the optical fiber cable can cause physical injuries. Dispose of the waste so that it will not cause any injuries.

2.6 Grounding and equipotential bonding

Effective grounding and equipotential bonding are very important for the interference immunity of PROFIBUS networks. Grounding and bonding is thus primarily to ensure correct functioning of PROFIBUS, and not for safety reasons. Proper grounding of the cable shield ensures that electrostatic interference is reduced, so minimizing pickup. Equipotential bonding ensures that the ground or earth potential is the same across the network. This, in turn, prevents ground currents flowing through the PROFIBUS cable shield. The following information provides general guidance for the installation of grounding and equipotential bonding.

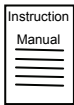

Please read the manufacturer's documentation. The instructions often provide information how to best achieve good grounding and equipotential bonding of a PROFIBUS device.

2.6.1 Protective Earth

The protective earth is fundamentally provided to protect people from electrical shock. However, it also protects equipment and machines from damage caused by electrical faults. The protective earth operates by providing a circuit for fault currents to flow to earth so causing the protective fuse to break or contact-breaker to trip, so removing the electrical power supply from the equipment. The removal of electrical power by the fuse or contact-breaker ensures that there is no further danger of electrical shock or equipment damage.

The protective earth is labelled by the following symbol.



The protective earth is a part of the electrical system of the plant. Therefore this document does not describe the protective earth. In every case you have to observe the regulations for the protective earth.



Some PROFIBUS-devices have a protective earth terminal (particularly those with a secondary higher voltage power supply). In such cases, this terminal must be connected according to the protective earth regulations.

2.6.2 Functional Earth

The functional earth provides a stable zero-voltage reference point for device screening. The device casing and any additional shielding should be connected to the functional earth. In this way any electrostatic interference is diverted to earth rather than causing pickup in the device electronic circuits.

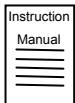

Read the manufacturer's instructions. Where available, these instructions may provide important information on how to connect the PROFIBUS-devices to the Equipotential Bonding system and the functional earth.

- Some PROFIBUS devices feature a functional grounding terminal. Connect the grounding terminal of the PROFIBUS station to the system ground. The grounding terminal is identified by the symbol for grounding (see right). The Protective earth terminal is independent from this and must always be tied to the protective earth of the system.
- For other devices, the grounding is carried out via the DIN-Rail. For this reason, you should also ground DIN-Rail.



Functional Earth
Symbol

- Use copper cables with an appropriate cross section ($> 2.5 \text{ mm}^2$) for the grounding connection of the PROFIBUS stations. Grounding cables generally feature a green-yellow insulation. In some countries, the green-yellow identification is mandatory (green in the US).

2.6.3 Equipotential bonding

The equipotential bonding system is used to equalize the earth potential at different locations of the plant so that no current flows over the shielding of the PROFIBUS-cable.

- Use copper cables or galvanized ground strips for the equipotential bonding in the system and between system components.
- Connect the equipotential bonding to the grounding terminal or bar with a large surface area.
- Connect all PROFIBUS device shield and ground connections (if available) to the equipotential bonding system.

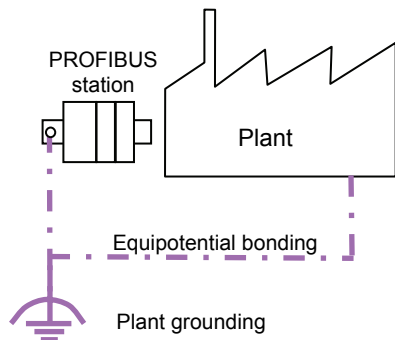
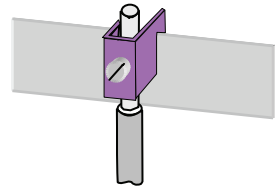

- Connect the mounting surface (for example cabinet panel or mounting rails) with the equipotential bonding system.
- Connect the PROFIBUS equipotential bonding system to the building equipotential bonding system as often as possible.

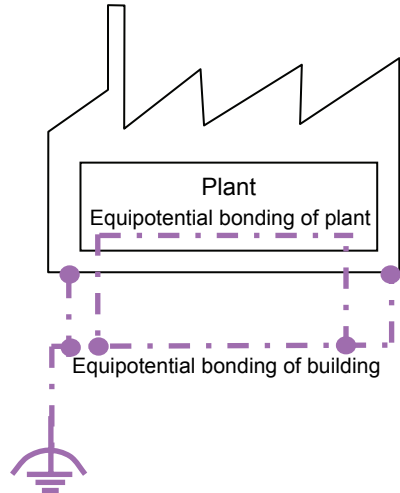

- If parts are painted, remove the paint from the connecting point before the connection.
- Protect the connecting point against corrosion after mounting, e.g. with zinc or varnish paint.
- Protect the equipotential bonding against corrosion. One option consists of painting the contact points.

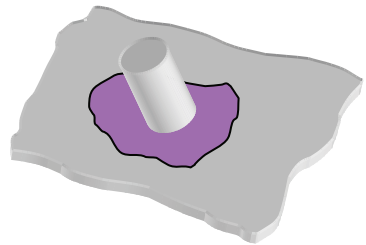

Assembling PROFIBUS cables

- Use secure screw or terminal connections for all ground and bonding connections. Use locking washers to avoid the connections becoming loose because of vibration or movement.
- Use wire-end ferrules or cable lugs for flexible equipotential bonding cables. The cable ends should never be tinned (no longer allowed)!
- Route the equipotential bonding as close as possible to the PROFIBUS cable.

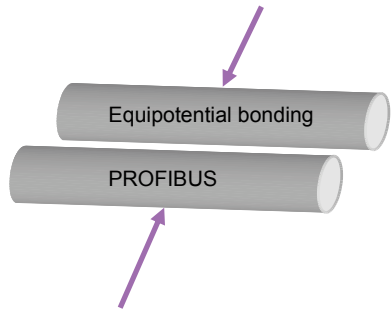

- Connect the individual parts of metal cable trays to each other. Use special bonding links or jumpers for this purpose. Ensure that bonding links are made from the same material as the cable trays. Cable tray manufacturers will be able to supply appropriate bonding links.

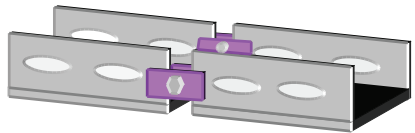

- Connect cable trays made out of metal as often as possible with the equipotential bonding system.

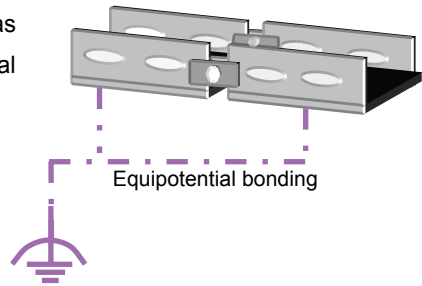

- Use flexible bonding links for expansion joints. Bonding links are available from cable manufacturers.

- For PROFIBUS connections between different buildings or parts of buildings, you must route an equipotential bonding parallel to the PROFIBUS cable. Maintain the following minimum cross sections according to IEC 60364-5-54:

- Copper 6 mm²
- Aluminum 16 mm²
- Steel 50 mm²

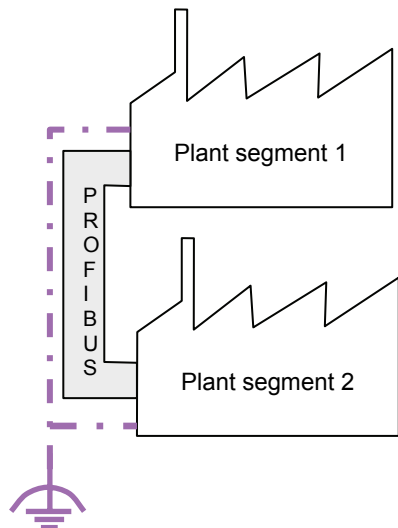

2.6.4 Connecting the shielding with the equipotential bonding

The shield is a necessary part of the PROFIBUS copper cable. It shields the two data cores in the cables against electrostatic interference. For the shielding to be effective, it must be connected to the equipotential bonding system. Ungrounded

shielding has no effect whatsoever. The PROFIBUS copper cable shield must be connected with the equipotential bonding system at the following points:

At the PROFIBUS station

- Connect the PROFIBUS cable shield to the equipotential bonding at every PROFIBUS station.

- The PROFIBUS connector, where used, provides connection for the cable shield. However, this requires a properly made the shield connection in the connector. Additional information about the connector assembly can be found in chapter 2.

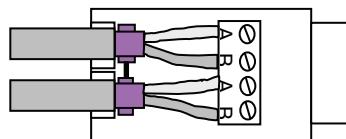

OK

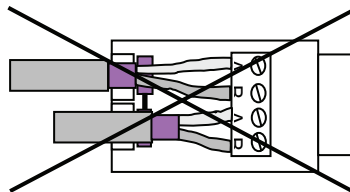

No

- PROFIBUS stations with direct PROFIBUS cable connection generally also offer an option for connecting the cable shield with the equipotential bonding. If the PROFIBUS cable is correctly assembled, no additional connection of the PROFIBUS cable shield is required. Additional information about the direct connection of PROFIBUS stations can be found in chapter 2.6.

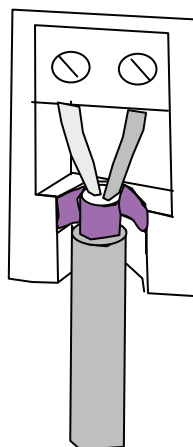

- If no shield connection exists, the shielding of the PROFIBUS cable must be connected to the equipotential bonding as close as possible to the PROFIBUS station. Additional information about establishing the connection between shielding and equipotential bonding can be found in chapter 2.6.5.
- If the PROFIBUS station features a ground terminal, it must also be connected with the equipotential bonding.

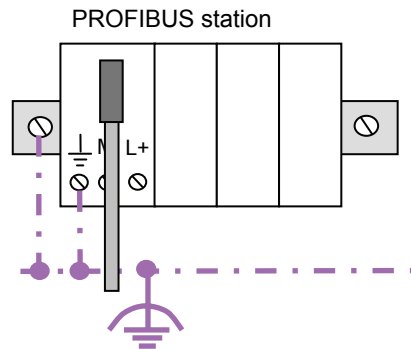

- Connect the mounting bracket (e.g. mounting rails) with the equipotential bonding system. For some PROFIBUS stations, the connection between shielding and equipotential bonding is established via the mounting screws.

At the cabinet entry

- Connect the PROFIBUS cable shield to the equipotential bonding at the entry point to a control cabinet. The connection should use a large surface area. This prevents any outside interference picked up on the PROFIBUS cable from being transmitted into the cabinet.
- For this purpose, attach an equipotential bonding rail at the cabinet entry behind the cable strain relief.
- Methods of connecting the cable shield to the equipotential bonding are described in chapter 2.6.5.

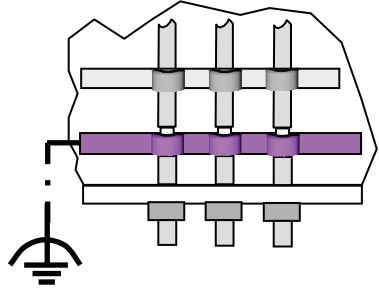

At the building entry

- Connect the shield of the PROFIBUS cable directly with the equipotential bonding system at the building entry point. The connection should have a large surface area to provide minimum resistance.
- For this purpose, attach an equipotential bonding rail at the building entry.

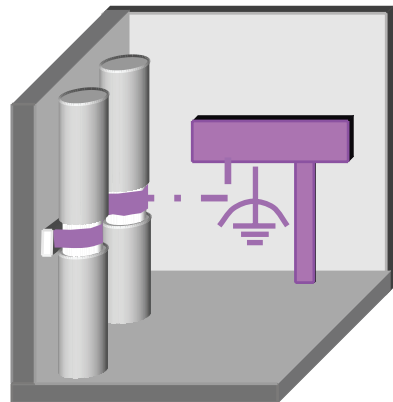

2.6.5 Equipotential bonding and earthing of PROFIBUS MBP (PA)

Generally there is no difference between the configuration of the equipotential bonding for PROFIBUS-RS 485 and PROFIBUS-MBP (PA). For electromagnetic compatibility (EMC) reasons you should connect the shield of the PROFIBUS MBP (PA) cable to the equipotential bonding system at both ends.

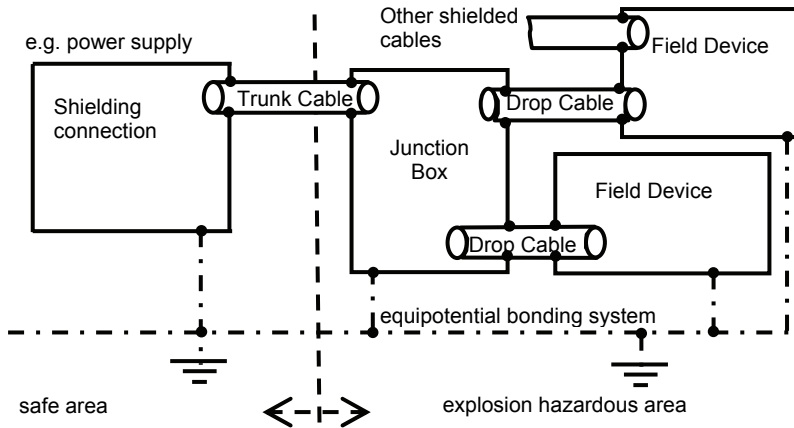

Fig. 16: Ideal connection of cable shields to the equipotential bonding

Fig. 16 shows the preferred way to connect the cable shields. In order to assure the explosion protection in hazardous areas it is mandatory to have a reliable equipotential bonding. In cases where this is not possible, the cable shield can be grounded on one side of the cable via a capacitor. In this case the national rules and regulations for installations in hazardous areas apply. In addition to that, the following rules have to be observed:

- Connect the equipotential bonding system with all metal parts in the hazardous area.
- Connect all PROFIBUS cable shields in the hazardous area with the equipotential bonding system.

- Connect the shield of the PROFIBUS Cable between the safe area and the hazardous area only in the hazardous area with the equipotential bonding system.
- Connect the shield of the PROFIBUS cable between the safe area and the hazardous area via a capacitor with the equipotential bonding system in the safe area. To fulfill the requirements of explosion protection, the capacitor should not create a short circuit in case of failure and must have the following properties:
 - Solid dielectric, e.g. ceramic
 - capacitance $\leq 10 \text{ nF}$
 - maximum rated voltage $>1500\text{V}$

The capacitor shall be connected to the shield of the cable (running from the hazardous area to the safe area) and the equipotential bonding system in the safe area with a low impedance. This means using short connections. Insulation distances to other circuits in the non hazardous area have to be observed.

- Connect the equipotential bonding system of the hazardous area to earth at only one point.
- Connect the equipotential bonding system to the earth in the safe area.

Fig. 17 shows the grounding of the cable shield via a capacitor.

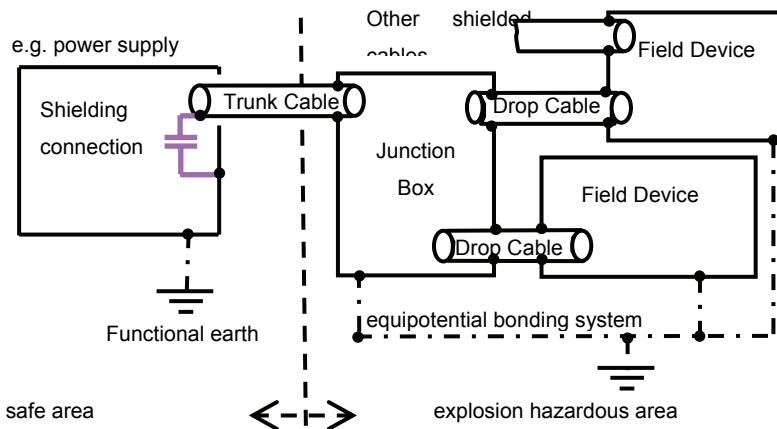

Fig. 17: Capacitive earthing for PROFIBUS-MBP (PA)

Assembling PROFIBUS cables



Make sure that the devices you use are approved for capacitive grounding of the cable shield by the manufacturer. In any case the national rules and regulations for installations in hazardous areas apply.

2.6.6 Connection of shielding to equipotential bonding

Several options are available for establishing the large-area connection between the shielding and the equipotential bonding system. The following figure shows various techniques that have proved themselves in the field.

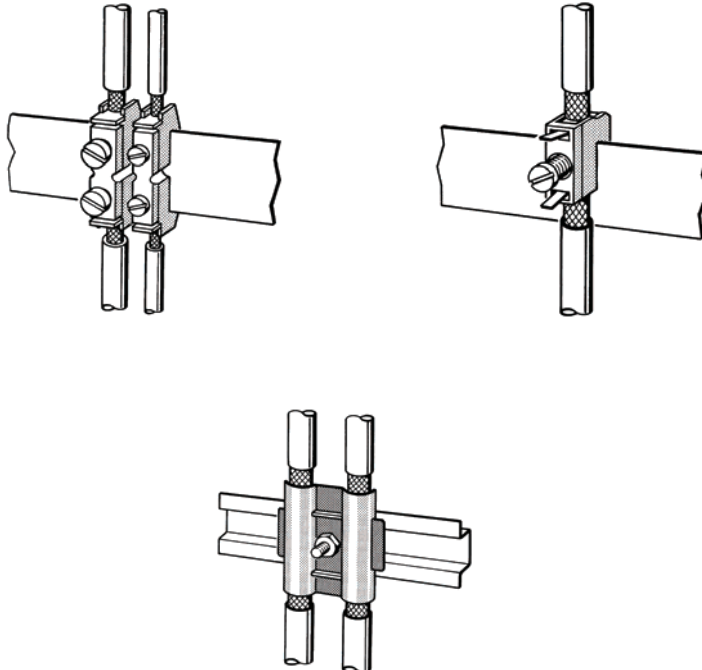
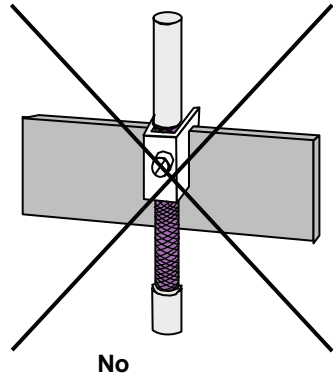
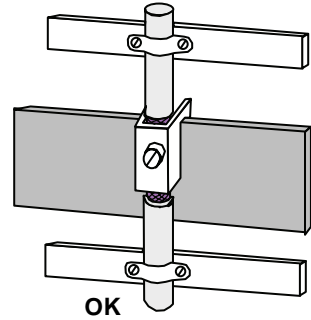

Fig. 18: Techniques for connecting the cable shield to equipotential bonding

- Ensure that the PROFIBUS cable is not pinched by the shield connection clamp. Use a shield clamp that fits the cable diameter.
- Pinching can deteriorate the transmission characteristics of the PROFIBUS cable.

The following must be observed when making the shielding connection:

- Only remove the PROFIBUS cable outer insulation where required for bonding. PROFIBUS cable is weakened where the sheath is removed.



- Ensure that you do not damage the braided shield when the outer insulation is stripped from of the PROFIBUS cable.

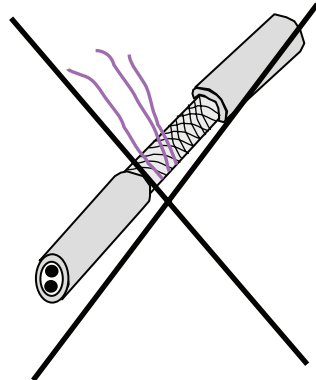

- Do not use the shield connection as a strain relief since this may reduce the effectiveness of the bonding and may cause the cable shield to be damaged. An exception would be when using parts that are specifically designed for this purpose.

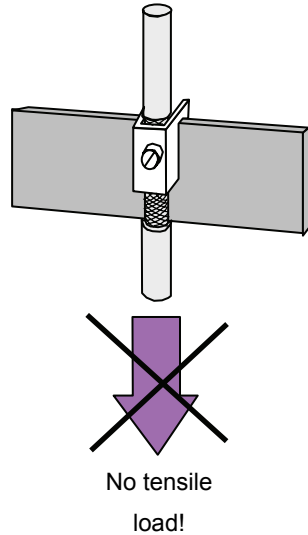

- To protect the weakened PROFIBUS cable from damage, it should be secured either side of the bonding connection.
- Use only parts that match the diameter of the stripped cable.

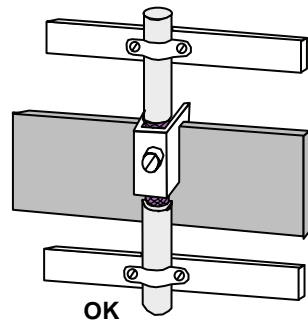

- The connection between the shield and the equipotential bonding must only be made using the braided screen. Many PROFIBUS cables also feature a foil screen. This foil must not be used for the connection. It is generally synthetically coated on one side to improve stability and the plastic coating acts as insulation.

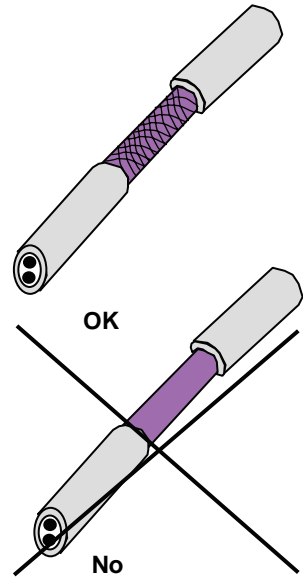

- Do not attach the equipotential bonding rail to painted surfaces. Galvanized or plated surfaces are well-suited for this purpose.
- Use tinned, galvanized or other galvanically treated material. Ensure the surface is protected against corrosion to ensure a permanent contact.

3 Connection of PROFIBUS stations

3.1 Static electricity (ESD)

Everyone will probably have encountered static electricity, or electrostatic charging. One touches a door handle or some other metal part and receives an electric shock. Electrostatic charging is created through friction of two objects isolated from each other. This can be, for example, running with shoes with a synthetic sole on a plastic flooring or the friction of synthetic clothes. The generated electrostatic charging can measure up to 10,000 V. Upon touching a grounded metal part, an electric discharge similar to lightning occurs.

Electronic components are very sensitive to high voltages. If the discharge of the electrostatic charge occurs via an electronic component the component may be damaged. For this reason, you should observe the following safety rules when handling PROFIBUS devices to prevent the electronics from being destroyed.

- Before handling PROFIBUS components, touch a grounded metal part. This allows your body to be discharged.

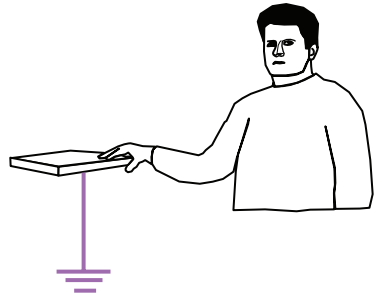

- Do not touch the plug or screw contacts of the device.

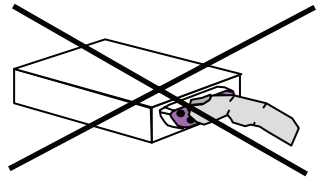

Connection of PROFIBUS cables

- Touch connectors only at the housing when you connect them.

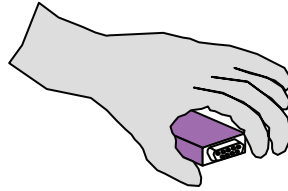

- Disconnect the PROFIBUS cable from all PROFIBUS stations before starting to work with the PROFIBUS cable. Assemble PROFIBUS cables with connectors at both ends before connecting it to a PROFIBUS station.

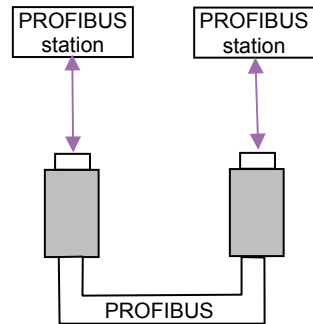

- In case of directly connected cables, touch the insulation and not the cores.

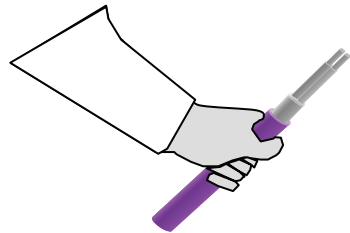

3.2 Connecting PROFIBUS stations via plug connections

Plug connection is the most frequent type of connection for PROFIBUS stations. Most of the devices using RS-485 transmission technology and copper cables are equipped with a 9-pin Sub-D plug connection. In addition, M-12 plug connections are used for RS-485 transmission technology as well as for PROFIBUS-MBP (PA) transmission. However, the two connector variants differ slightly from each other.

Station connection using connectors is very simple. After assembling the PROFIBUS cable, the plug connection only needs to be pushed into the station socket. The shield connection of the PROFIBUS cable with the PROFIBUS station is also carried out via the plug connection.

The following instructions apply to all types of plug connections for copper cables. The connectors shown in the following diagrams are examples only.

- Due to their construction, twisting the connectors is generally not possible. To prevent damage, check how the plug and socket fit together before making the connection. This is particularly important for M-12 plug connections.

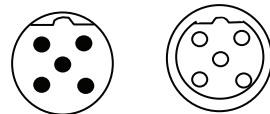

OK

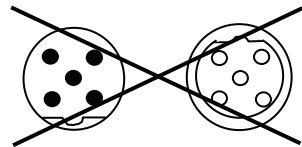

No

- Touch connectors only at the housing.

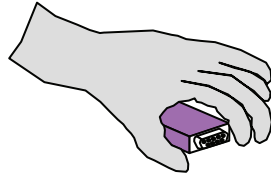

- Do not apply excessive force when connecting the plug connection.

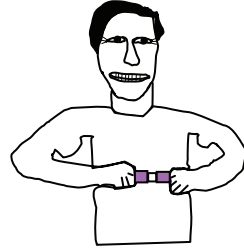

- In case of tightness, check the plug pins. In the case of bent pins, replace the connector.

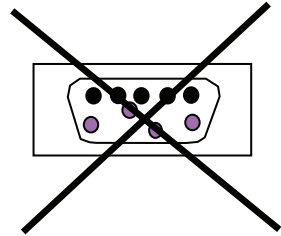

- Tighten the connector fastening screws after making the connection. They are a part of the strain relief system. In addition, they will avoid the connector becoming loose.

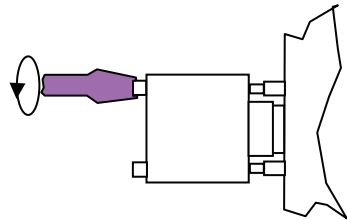

If an integrated bus termination exists, observe the switch setting. It should only be activated at the two ends of the segment.

4 Installations with safety technology (PROFIsafe)

PROFIBUS DP supports the operation of safety relevant devices (such as light curtains, remote I/O, drives with integrated safety, etc.) via the safe communication protocol "PROFIsafe". Special care must be taken with these applications with assembling, cabling and commissioning due to potential hazards for people and equipment.

The following provides some general rules on how to proceed in these cases:

- Each and every device on PROFIBUS DP (standard and safety) shall provide a PROFIBUS test certificate or at least a corresponding manufacturer declaration.
- Each and every safety device shall provide a safety certificate by a "Notified Body" (e.g. TÜV, BIA, HSE, INRS, UL, etc.).
- The 24V power supplies in use shall be one-error proof and provide SELV / PELV only. In the USA the power supplies shall provide a current limitation of 8A (UL508C).
- No spurs or branch lines are permitted in a RS485 segment.
- Ensure effective cable shielding especially after bending the cable or after changing connectors. In case of doubt, a more flexible and robust cable type should be used.
- Sub-D connectors shall have multi contact features at the connector housing in order to provide an optimal contact between the cable shield, the cable connector and its counterpart at the PROFIBUS device. Please take care to achieve a good (low impedance) contact between the cable shield and connector housing.
- Use only M12 connectors that guarantee a good contact between cable shield and connector housing. Certain instruction manuals require wiring from the cable shield to the connector PIN 5. In case of doubt, it is more important to connect the cable shield to the connector housing using the largest possible contact area.
- The power cabling for drives and motors shall be carried out using 5 wire cables that keep the "N" line and the "PE" lines separate (so-called TN power networks). Thus currents due to potential differences and electro-magnetic inference can be avoided as much as possible.
- A cabinet of protection class IP54 (dust, shower water) is normally used for safety devices that are offering a lower protection class such as IP20. Cabinets

with a lower protection class may only be used if safety devices explicitly permit other environments according to the manufacturer's information (e.g. heat problems).

It is highly recommended to create records after a visual check of the plant. Whenever possible the quality of the network shall be documented: no double addressing, no reflections, no repeat telegrams, etc.

5 Terms / Definitions

DIN

German Institute for Standardization (www.din.de)

EN (European Standard)

The official standard that is recognized and applied by all European countries that are member of the European union. Many of the IEC standards are also accepted as EN standards.

Fiber Optic (FO)

In industrial environments it may happen, that an usual bus physic in copper technology makes problems because of EMC interference. This problem can be solved by using optical fiber technology. See "Optical Data Transmission".

Hazard

IEC 61508-4: Potential source of harm. The term includes danger to persons arising within a short time scale (for example, fire and explosion) and also those that have a long term effect on a person's health (for example, release of a toxic substance).

IEC

International Electrotechnical Commission (located in Geneva, CH)

Ingress Protection (IP)

IEC/EN 60529: The IP Code indicates the degree of protection provided by enclosures for electrical equipment, e.g. IP67. The first numeral indicates protection of persons against access to dangerous parts and protection of internal equipment against the ingress of solid foreign objects.

0 - No Protection

1 - Protected against solid objects > 50mm, e.g. accidental touch by hands

2 - Protected against solid objects > 12mm, e.g. fingers

3 - Protected against solid objects > 2.5mm, e.g. tools and wires

4 - Protected against solid objects of 1mm, e.g. tools, wire and small wires

5 - Protected against dust (limited ingress permitted)

6 - Protected against dust (totally)

The second numeral indicates protection of internal equipment against harmful ingress of water.

0 - No Protection

1 - Protected against water falling vertically (condensation)

2 - Protected against direct sprays up to 15° from vertical

3 - Protected against direct sprays up to 60° from vertical

4 - Protected against sprays from all directions (limited ingress permitted)

5 - Protected against low pressure jets from all directions (limited ingress permitted)

6 - Protected against high pressure jets from all directions. (limited ingress permitted), e.g. for use on shipdecks.

7 - Protected against immersion between 15 cm and 1 m

8 - Protected against immersion under pressure

Intrinsic safety (Ex i)

A type of protection in which a portion of the electrical system contains only intrinsically safe equipment (apparatus, circuits and wiring) that is incapable of causing ignition in the surrounding atmosphere. No single device or wiring is intrinsically safe by itself (except for battery-operated self-contained apparatus such as portable pagers, transceivers, gas detectors, etc., which are specifically designed as intrinsically safe self-contained devices) but is intrinsically safe only when employed as part of a properly designed intrinsically safe system.

MBP (PA) and MBP (PA)-IS

Refers to the transmission technology PROFIBUS Manchester-coded & Bus-powered. PROFIBUS-MBP (PA) is used for the data transfer with PROFIBUS PA. MBP (PA)-IS is the intrinsic safety version of MBP (PA).

Optical Data Transmission

IEC 61158-2: Type of medium attachment unit (MAU) with the following characteristics:

- Fiber optic cable (FOC) manufactured from quartz or plastic
- Large range, independent of the transmission speed
- Insensitivity to electromagnetic disturbance

- Galvanic isolation between the connected stations
- Star, ring, line and mixed topologies (tree)
- Connection to electrical network segments
- Data rates: 9,6/ 19,2/ 45,45/ 93,75/ 187,5/ 500 kbit/s; 1,5/ 3/ 12 MBit/s

Possible Fiber optic cables

- Multi-mode glass fiber
- Single-mode glass fiber
- Plastic fiber
- HCS glass fiber (step index, Hard Clad Silica)

PROFIBUS

IEC 61784-1: Communication network according communication profile family 3 (CPF3); incorporating application profiles and system integration aspects like interfaces and languages for engineering tools and HMI.

PROFIBUS is an open, digital communication system with a wide range of applications, particularly in the fields of factory and process automation. PROFIBUS is suitable for both fast, time-critical applications and complex communication tasks.

PROFIBUS cables

Medium for digital data transmission, implemented as copper cable or optical fiber cable

PROFIBUS components

Refers to all components that make up a PROFIBUS network (e.g. cables, connectors, master/slave interfaces, repeaters, etc.)

PROFIBUS Device

Device that communicates with other devices via the PROFIBUS cable (master, slave)

PROFIBUS DP

Acronym for "PROFIBUS for Decentralized Peripherals".

PROFIBUS user organisation (PNO)

The PNO is the German Regional Association of PROFIBUS International, (PI). PROFIBUS International (PI) has engaged PNO (PROFIBUS Nutzerorganisation e. V.), Germany to establish Technical Committees (TC) and Working Groups (WG) in order to define and maintain the open and vendor independent PROFIBUS technology. PNO was founded in 1989. PNO is a non-profit organization with its headquarter in Karlsruhe, Germany. Members of PROFIBUS International have the right to join the Technical Committees (TC) and Working Groups (WG) of PNO. A member may take an active part in maintenance and further development of the PROFIBUS technology. This guarantees openness and vendor independence of the PROFIBUS technology. See "www.profibus.com" for details.

PROFIBUS PA

Refers to "PROFIBUS for Process Automation". This is an application profile based on the communication protocol PROFIBUS DP and independent of the physical layout (RS 485, optical, MBP (PA)). The requirements for continuous production processes are covered in the application profile "PA devices" in combination with MBP (PA).

Programming Unit (PU)

According to the size of a particular PLC several types of programming devices and/or software are provided by the manufacturer:

- Single instruction programmer attachable to the PLC. This programmer is useful for a small edit of an existing program.
- Usually a dedicated manufactures computer hardware and software (PC compatible) for dedicated programming languages such as ladder logic including special features for the support of automation applications or for industrial environment. These programming units are completed to engineering tools thus enabling all the commisssioning steps.
- PC compatible software to allow a standard desktop or laptop computer to be the programming unit. In order to complete the system to an engineering tool additional hardware is required, e.g. a PROFIBUS DP interface.

RS 485

Refers to the standard transfer technology for PROFIBUS that operates with a data transfer technology according to the RS-485 standard. PROFIBUS RS 485 is used for the data transfer with PROFIBUS DP. It allows high data transfer rates and is primarily used in factory automation.

RS 485-IS

names a PROFIBUS transmission technology on a 4-conductor-basis (separate data- and supply lines) which operates according to the RS-485 standard with adaptations that enable the use in explosion protected areas of protection-type EEx i. IS refers to Intrinsic Safety.

Terminator

IEC 61158-2: A resistor connecting conductor pairs at both ends of a wire medium segment to prevent reflections from occurring at the ends of cables. Ideally it should be the wave impedance of the wire.

Additional terms for PROFIBUS can be found in the PROFIBUS glossary under www.profibus.com.

6 Index

9-pin Sub-D connector	
Insulation displacement method.....	59
Screw terminals.....	56
Assembling PROFIBUS cables.....	49
9-pin Sub-D plug connection.....	53
Assembling connectors.....	53
BFOC/2.5 connectors.....	82
Connecting the shielding with the equipotential bonding.....	91
Direct connection of PROFIBUS stations.....	75
Fiber connectors for PROFIBUS.....	82
Flexible PROFIBUS cables.....	78
Glass optical fiber cable.....	84
Hybrid connectors.....	71
Insulation displacement method.....	59, 68
M-12 connectors.....	61
optical fiber cables.....	81
Other connector types.....	82
Plastic optical fiber.....	82
PROFIBUS termination.....	50
Screw terminals.....	56, 65
Wire-end ferrules.....	See Flexible PROFIBUS cables
Electrical safety – assembling.....	9

Index

Cable damage	10
Grounding	See Equipotential bonding
Grounding and equipotential bonding	86
capacitive grounding	95
Equipotential bonding.....	88
Functional earth	87
PROFIBUS-MBP.....	95
protective earth	86
Installations with safety technology	109
M12 connector	
Insulation displacement method.....	68
PROFIBUS MBP	63
PROFIBUS RS 485.....	61
Screw terminals.....	65
PROFIBUS termination	50
PROFIsafe	109
Routing PROFIBUS cables	15
Bending radiuses	36, 46
Cable routing inside of buildings	22
Cable routing inside of control cabinets	19
Cable routing outside of buildings	24
Cable spacings.....	16
Compression loads	35
Connector of optical fiber cable.....	42
Considerations after installation	39, 48
Copper cable.....	16
Electrical safety during the assembling	9
EMC interferences of optical fiber cables	48
Laying of optical fiber cables	40
Laying the cables	31
Looping	37, 47
Mechanical load of optical fiber cable	43

Index

Mechanical protection of PROFIBUS cables.....	30
minimum cross section of equipotential bonding.....	27
Minimum cross section of equipotential bonding.....	91
Minimum spacings	16, 18, 19, 22
Optical fiber cable	29
Pulling supports.....	34
Pulling supports for optical fiber cables.....	45
Redundant PROFIBUS cables.....	29
Routing in the ground.....	See Cable routing outside of buildings
Routing of PROFIBUS cables	16
Sharp edges.....	38, 48
Storage and transport	31, 40
Strain relief.....	34, 45
Telecommunication cable	16
Temperatures.....	32, 41
Tensile strength.....	33, 41
Torsion	35
Trailing and garland cables	35
Twisting.....	35

7 References

References

PROFIBUS Interconnection Technology V1.1., Order No 2.142, PROFIBUS Nutzerorganisation, Karlsruhe, Germany

Optische Übertragungstechnik für PROFIBUS, V2.0., Order No 2.021, PROFIBUS Nutzerorganisation, Karlsruhe, Germany

Installation Guideline for PROFIBUS DP/FMS, V1.0., Order No 2.112, PROFIBUS Nutzerorganisation Karlsruhe, Germany

PROFIsafe Requirements for Installation, Immunity and electrical Safety, V1.0, Order No 2.232, PROFIBUS Nutzerorganisation, Karlsruhe, Germany

PROFIBUS PA User and Installation Guideline, V2.2., Order No 2.092, PROFIBUS Nutzerorganisation, Karlsruhe, Germany

PROFIBUS RS 485-IS User and Installation Guideline V1.1, Order No 2.262, PROFIBUS Nutzerorganisation, Karlsruhe, Germany

PROFIsafe - Requirements for Installation, Immunity and electrical safety, V 1.1, Order No. 2.232, PROFIBUS Nutzerorganisation, Karlsruhe, Germany

PROFIBUS Glossary, Date 30.01.04, PROFIBUS Nutzerorganisation, Karlsruhe, Germany

Handbuch SIMATIC Net PROFIBUS Netze Version 2, Date 5/2000, Bestellnummer 6GK 1970–5AC20–0AA0, Siemens AG, Bereich Automatisierungs- und Antriebstechnik, Geschäftsgebiet Industriellen Kommunikation, Nürnberg, Germany

Handbuch System Ecofast , Date 11/2003, Bestellnummer 3RK1703-0AB18-0AA0, Siemens AG, Bereich Automatisierungs- und Antriebstechnik, Amberg, Germany

Description HARTING RJ Industrial® Abmantelwerkzeug Version 1.0, Date 10/2003, HARTING Electronics GmbH & C0. KG, Espelkamp, Germany

References

Description Assembly manual *HARAX*® screened version, Date 7/2004, Electronics GmbH & Co. KG, Espelkamp, Germany

Assembly description M12 Connector, Date 10/2000, Franz Binder GmbH & Co. KG, Neckarsulm, Germany

Mitchell, Ron: PROFIBUS – A pocket guide, Date 2004, ISBN 1-55617-862-X, ISA-The Instrumentation, Systems and Automation Society, Research Triangle Park

Popp: The New Rapid Way to PROFIBUS DP, Order No. 4.072, Date 03/2003

Fieldbus Wiring Design and Installation Guide, RELCOM Inc Forest Grove, USA

www.profibus.com, Date 26.05.2004

www4.ad.siemens.de/dnl/jE1Nzg1AAAA_2415604_HB/BT200_V2_d.pdf,
Date 10.05.2004

www.hms-networks.de/pdf/Shortform_Bustest_II_D.pdf, Date 10.05.2004

www.comsoft.de/html/icpd/profibus/analysis/nettest.htm, Date 10.05.2004

Addresses

PROFIBUS International Competence Center

PROFIBUS International Competence Center (PICC), accredited by PNO, are qualified partners for all questions regarding PROFIBUS and located all over the world. The services offered by the PICCs range from a telephone hotline, support for field device development, troubleshooting in systems through the organization of specific, problem-oriented workshops. These impart not only the fundamental principles of PROFIBUS, facilitating entry to the technology, but also detailed information that provides developers with information on how to develop field devices. The current contact addresses can be obtained at www.profibus.com area support.

© Copyright by

PROFIBUS Nutzerorganisation .e.V.

Haid-und-Neu-Str. 7

76131 Karlsruhe

Germany

Phone: +49 721 / 96 58 590

Fax: +49 721 / 96 58 589

info@profibus.com

www.profibus.com

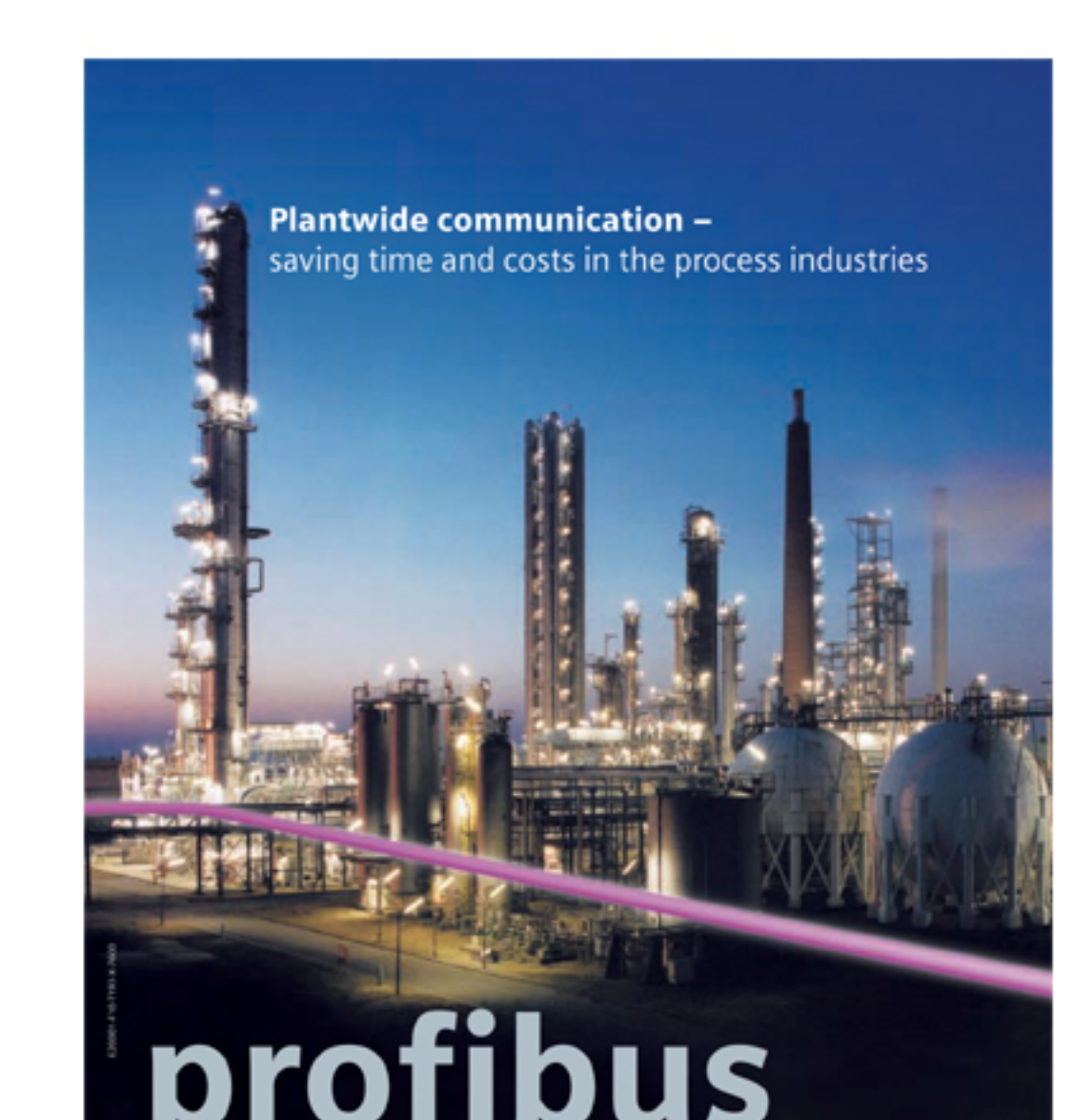

Plantwide communication –
saving time and costs in the process industries

© 2006 Siemens AG 6ES7 311-1EX00-0AB0

profibus

Process industry plants with a mix of continuous, batch, discrete and safety applications require a fieldbus that handles the challenges of such a hybrid environment. PROFIBUS is the only fieldbus which provides access to data from all plant components, in a single uniform manner, across the entire production chain. The result is a "complete" solution – all under a single fieldbus – improving profitability and maximizing productivity and performance for your people and plants.

Want to reduce the Total Costs of Ownership of your assets? To learn more about the benefits of a Totally Integrated Automation solution utilizing PROFIBUS products from Siemens, please visit us under www.siemens.com/processautomation or send a fax to Siemens Infoservice +49 (911) 978 33 21, Infoservice AD/2 1170.

SIEMENS

www.siemens.com/processautomation



closer contacts



LioN-M



LioN-S

Universal I/O functionality, space-saving design and easy handling

Whatever the wiring in your Profibus field area is to look like – with only one I/O module you can realize the most diverse configurations.

Decide for yourself, which sensors or actuators are connected with which I/O ports. The new IP 67 I/O modules can be easily integrated into Profibus, just plug and play.

www.lumberg.com/lion



lumberg



HIRSCHMANN

Hirschmann. Simply a good Connection.



Fiber optic Profibus Repeater **OZD Profi 12M**

- The first choice in EMC polluted environment
- Conformal coating for harsh environment
- ATEX and FM approvals for hazardous locations
- Extremely fast redundancy
- Preventive maintenance possibility

WWW.HIRSCHMANN.COM

LEONI FieldLink®



Ethernet cables for PROFINET

- permanent installation
- trailing and robotic application
- with maritime approvals and a variety of custom designed solutions

THE QUALITY CONNECTION

LEONI

Wire - Cable - Wiring Systems

www.leoni-special-cables.com

KERPEN

Competence in Cable Technology

ICON™

Bus-Programme

Cables for Bus-Systems



PROFIBUS PA and FMS/DP

- Large Range of Products on Stock

- Solutions for Standard- & Specialised Applications



www.kerpen-industrial.com

KERPEN GmbH & Co. KG

Zweifaller Str. 275-287 • D-52224 Stolberg, Germany
email: industrial@KERPEN.com • Tel: 0 24 02 / 17 307



Reliable Cooperation: HARTING Network Components

HARTING as a specialist in connectors for harsh industrial environments offers optimal installation solutions together with their competence in industrial data networks. The network based components with the M12 interface along with the appropriate system cables allow an universal connection with M12 circular connectors.

- HARTING offers installation solutions
- for the future.

HARTING Electric GmbH & Co. KG | Wilhelm-Harting Straße 1 | D-32339 Espelkamp | Phone: +49 (0) 571 47-47100
 Fax: +49 (0) 571 47-491 | HARTING.Electric@HARTING.com | www.HARTING.com

LEONI Fiber Optics



Your Specialist for Fiber Optics

Various cable and fiber types for high mechanical and chemical resistance in your area of industrial application. Fiber optic cables and connectors for all known brands of fieldbus systems.

THE QUALITY CONNECTION

LEONI

Wire - Cable - Wiring Systems

www.leoni-fiber-optics.com

Analyzer on USB



ProfiTrace

ProfiTrace is an innovative and essential tool for installation, engineering and maintenance work. Eliminate down times and increase the availability of your PROFIBUS installation.

- Simple user interface
- Instant network statistics
- Up to 12Mbit/s
- USB interface



PROFIBUS Center Netherlands,
 Tel.: +31 (0)174-671800, Fax: +31 (0)174-671801,
www.profibuscen.nl/profitrace

2005-08

KERPEN

Competence in Cable Technology

MegaLine[®]

and

GigaLine[®]

Heavy Duty Copper & Fibre Optic Cables
 for Industrial Ethernet Applications



www.kerpen.com

KERPEN GmbH & Co. KG
 Zweifaller Str. 275-287 • D-52224 Stolberg, Germany
 email: info@KERPEN.com • Tel: 0 24 02 / 17 - 1

— Entirely PROFIBUS

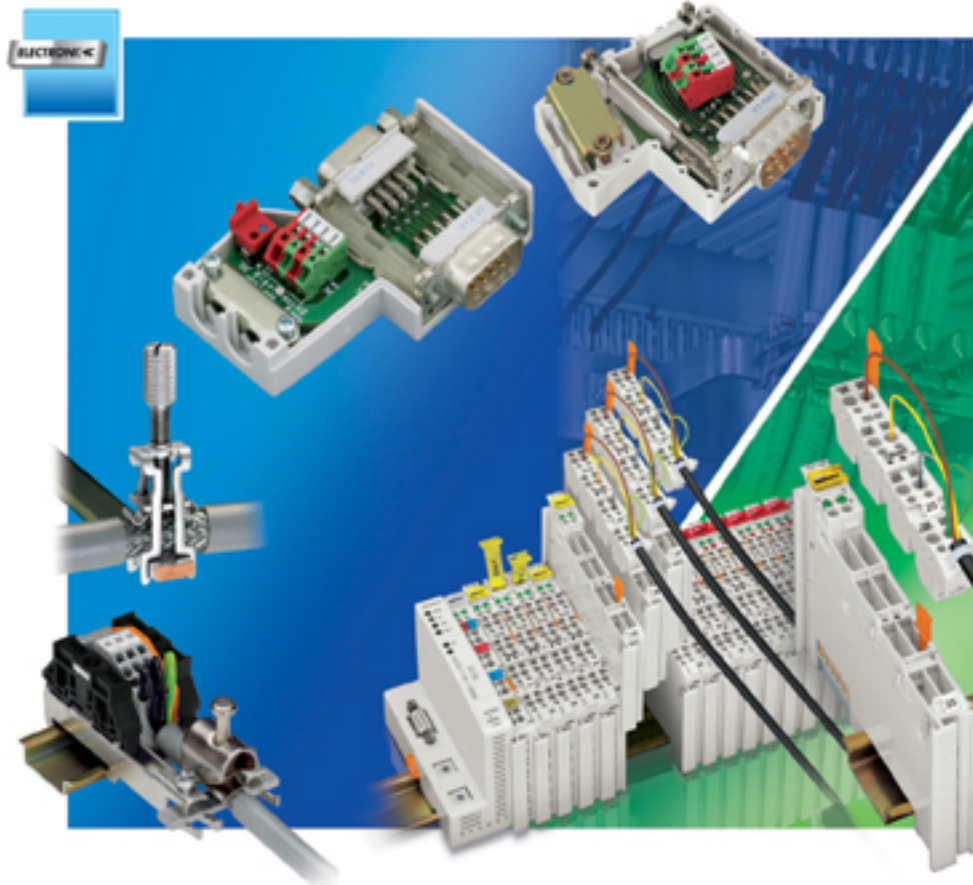

— Extending capabilities!

The range of WAGO PROFIBUS products does not end with the Series 750/753 fieldbus nodes of the WAGO-I/O-SYSTEM, which also include Exi and PROFIsafe components. Our fieldbus connectors with CAGE CLAMP® connections and actuation slide mechanisms make fieldbus cable wiring easy as child's play.

Finally, our versatile shield (screen) connecting system provides an EMC-compatible shield (screen) connection – on a busbar or directly to a chassis. WAGO – creating systems

www.wago.com

WAGO®
INNOVATIVE CONNECTIONS

Order No.: 8.022

05/2006

© Copyright by:
PROFIBUS Nutzerorganisation e.V.
Haid-und-Neu-Str. 7
76131 Karlsruhe
Germany
Phone: +49 721 96 58 590
Fax: +49 721 96 58 589
E-mail: info@profibus.com
Http: [//www.profibus.com](http://www.profibus.com)